

VERSAFLOW MAG 100 Quick Start

Electromagnetic flow sensor in sandwich design

The documentation is only complete when used in combination with the relevant documentation for the signal converter.

Honeywell

1	Safety instructions	4
<hr/>		
2	Installation	6
<hr/>		
2.1	Scope of delivery.....	6
2.2	Device description	7
2.3	Nameplate (example)	8
2.4	Storage	9
2.5	Transport	9
2.6	Pre-installation requirements	9
2.7	General requirements	10
2.7.1	Vibration	10
2.7.2	Magnetic field.....	10
2.8	Installation conditions	11
2.8.1	Inlet and outlet	11
2.8.2	Bends in 2 or 3 dimensions.....	11
2.8.3	T-section	11
2.8.4	Bends	12
2.8.5	Open feed or discharge	12
2.8.6	Flange deviation	13
2.8.7	Control valve	13
2.8.8	Pump	13
2.8.9	Air venting and vacuum forces	14
2.8.10	Mounting position.....	14
2.9	Mounting	15
2.9.1	Torques and pressures.....	15
<hr/>		
3	Electrical connections	18
<hr/>		
3.1	Safety instructions.....	18
3.2	Grounding	18
3.3	Virtual reference for TWM 9000	20
3.4	Connection diagrams	20
<hr/>		
4	Technical data	22
<hr/>		
4.1	Dimensions and weights	22
<hr/>		
5	Technical data	25
<hr/>		

Warnings and symbols used**DANGER!**

This information refers to the immediate danger when working with electricity.

**DANGER!**

These warnings must be observed without fail. Even partial disregard of this warning can lead to serious health problems and even death. There is also the risk of seriously damaging the device or parts of the operator's plant.

**WARNING!**

Disregarding this safety warning, even if only in part, poses the risk of serious health problems. There is also the risk of damaging the device or parts of the operator's plant.

**CAUTION!**

Disregarding these instructions can result in damage to the device or to parts of the operator's plant.

**INFORMATION!**

These instructions contain important information for the handling of the device.

**HANDLING**

- This symbol designates all instructions for actions to be carried out by the operator in the specified sequence.

RESULT

This symbol refers to all important consequences of the previous actions.

Safety instructions for the operator**CAUTION!**

Installation, assembly, start-up and maintenance may only be performed by appropriately trained personnel. The regional occupational health and safety directives must always be observed.

**LEGAL NOTICE!**

The responsibility as to the suitability and intended use of this device rests solely with the user. The supplier assumes no responsibility in the event of improper use by the customer. Improper installation and operation may lead to loss of warranty. In addition, the "Terms and Conditions of Sale" apply which form the basis of the purchase contract.

**INFORMATION!**

- *Further information can be found on the supplied CD-ROM in the manual, on the data sheet, in special manuals, certificates and on the manufacturer's website.*
- *If you need to return the device to the manufacturer or supplier, please fill out the form contained on the CD-ROM and send it with the device. Unfortunately, the manufacturer cannot repair or inspect the device without the completed form.*

2.1 Scope of delivery



INFORMATION!

Do a check of the packing list to make sure that you have all the elements given in the order.



INFORMATION!

Inspect the packaging carefully for damages or signs of rough handling. Report damage to the carrier and to the local office of the manufacturer.



INFORMATION!

The remote version will arrive in two cartons. One carton contains the converter and one carton contains the sensor.

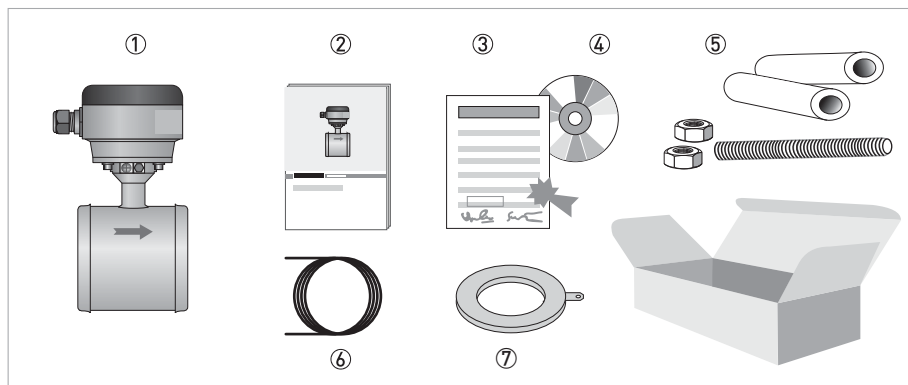

Figure 2-1: Scope of delivery

- ① Ordered flowmeter
- ② Product documentation
- ③ Factory calibration report
- ④ CD-ROM with product documentation in available languages
- ⑤ Mounting material (rubber sleeves). Optional; studs and bolts.
- ⑥ Signal cable (remote versions only)
- ⑦ Grounding rings (optional)



INFORMATION!

Assembly materials and tools are not part of the delivery. Use the assembly materials and tools in compliance with the applicable occupational health and safety directives.

2.2 Device description

Electromagnetic flowmeters are designed exclusively to measure the flow and conductivity of electrically conductive, liquid media.

Your measuring device is supplied ready for operation. The factory settings for the operating data have been made in accordance with your order specifications.

The following versions are available:

- Compact version (the signal converter is mounted directly on the measuring sensor)
- Remote version (a measuring sensor with a connection box and a separate signal converter)

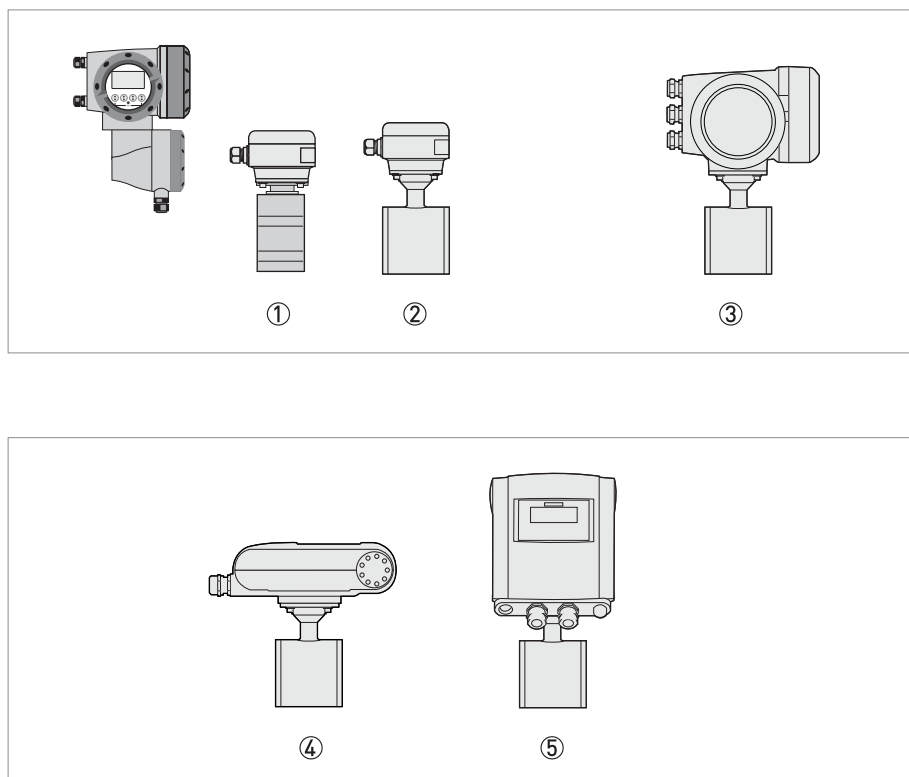

Figure 2-2: Device versions

- ① Remote version (DN10...40 - 3/8...1 1/2")
- ② Remote version (DN50...150 - 2...6")
- ③ Compact version with signal converter TWM 9000
- ④ Compact version with signal converter TWM 1000 (0°)
- ⑤ Compact version with signal converter TWM 1000 (45°)

2.3 Nameplate (example)



INFORMATION!

Check the device nameplate to ensure that the device is delivered according to your order. Additional information (e.g. correct supply voltage), can be found in the documentation of the signal converter.

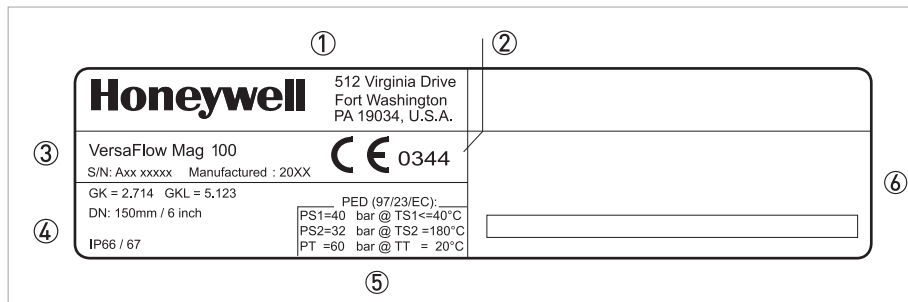

Figure 2-3: Example of nameplate

- ① Name and address of the manufacturer
- ② CE sign with number(s) of notified body / bodies
- ③ Type designation of the flowmeter and manufacturing date
- ④ Calibration data
- ⑤ PED data
- ⑥ Tag nr and approvals related information

2.4 Storage

- Store the device in a dry and dust-free location.
- Avoid lasting direct exposure to the sun.
- Store the device in its original packaging.
- Storage temperature: -50...+70°C / -58...+158°F

2.5 Transport

Signal converter

- No special requirements.

Compact version

- Do not lift the device by the signal converter housing.
- Do not use lifting chains.
- To transport the device, use lifting straps.

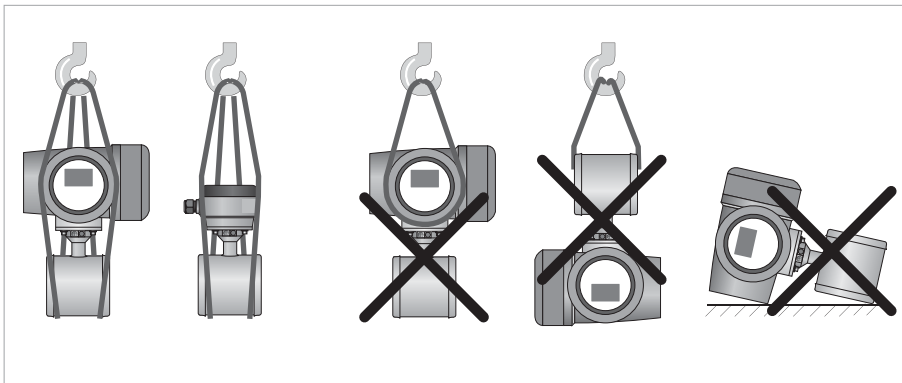

Figure 2-4: Transport

2.6 Pre-installation requirements

Make sure that you have all necessary tools available:

- Allen key (4 mm)
- Small screwdriver
- Wrench for cable glands
- Wrench for wall mounting bracket (remote version only)
- Torque wrench for installing flowmeter in pipeline

2.7 General requirements



INFORMATION!

The following precautions must be taken to ensure reliable installation.

- Make sure that there is adequate space to the sides.
- Protect the signal converter from direct sunlight and install a sun shade if necessary.
- Signal converters installed in control cabinets require adequate cooling, e.g. by fan or heat exchanger.
- Do not expose the signal converter to intense vibration. The flowmeters are tested for a vibration level in accordance with IEC 68-2-64.

2.7.1 Vibration

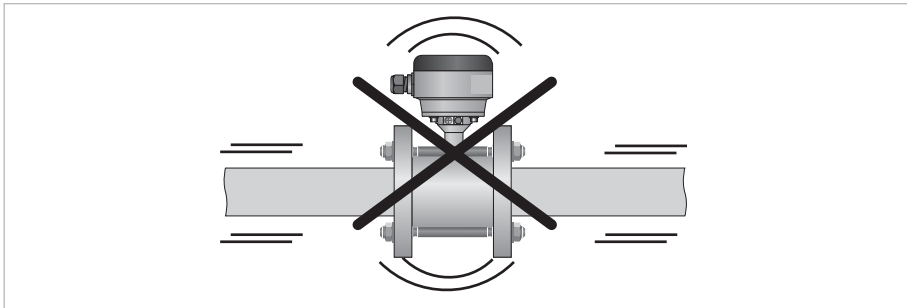

Figure 2-5: Avoid vibrations

2.7.2 Magnetic field

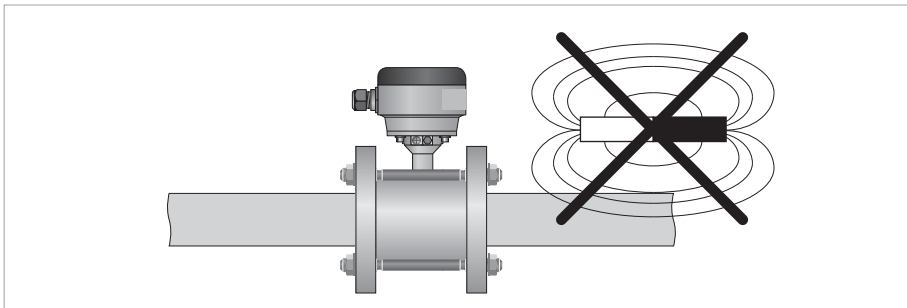

Figure 2-6: Avoid magnetic fields

2.8 Installation conditions

2.8.1 Inlet and outlet

Use straight inlet and outlet pipe sections to prevent flow distortion or swirl, caused by bends and T- sections

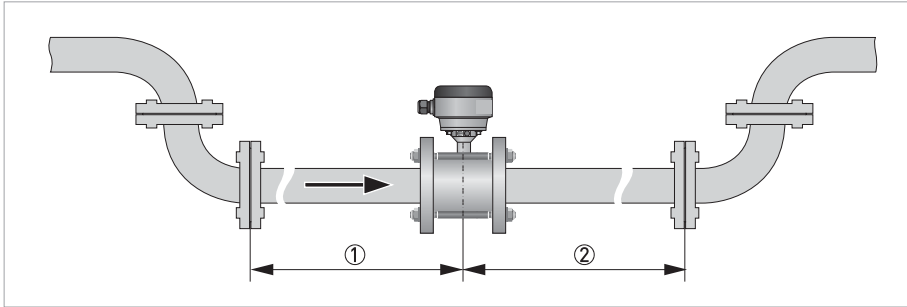

Figure 2-7: Recommended inlet and outlet section

- ① Refer to chapter "Bends in 2 or 3 dimensions"
- ② ≥ 2 DN

2.8.2 Bends in 2 or 3 dimensions

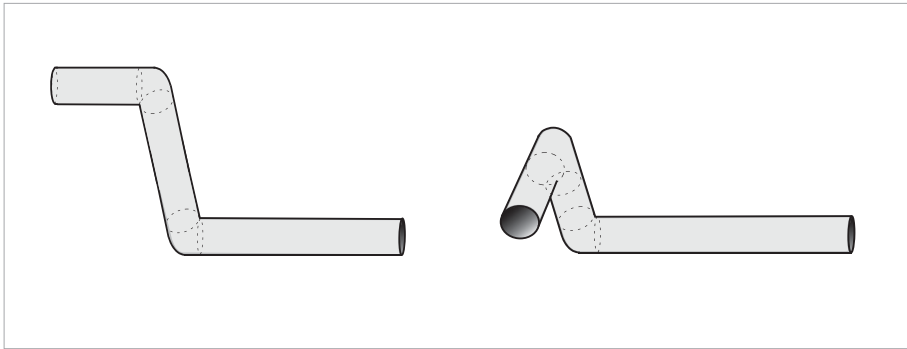

Figure 2-8: Inlet when using 2 and/or 3 dimensional bends upstream of the flowmeter

Inlet length: using bends in 2 dimensions: ≥ 5 DN; when having bends in 3 dimensions: ≥ 10 DN



INFORMATION!

2 Dimensional bends occur in a vertical **or** horizontal plane only, while 3 Dimensional bends occur in both vertical **and** horizontal plane.

2.8.3 T-section

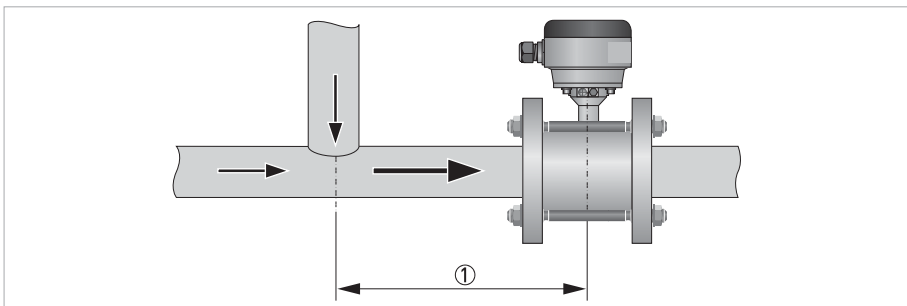

Figure 2-9: Distance behind a T-section

- ① ≥ 10 DN

2.8.4 Bends

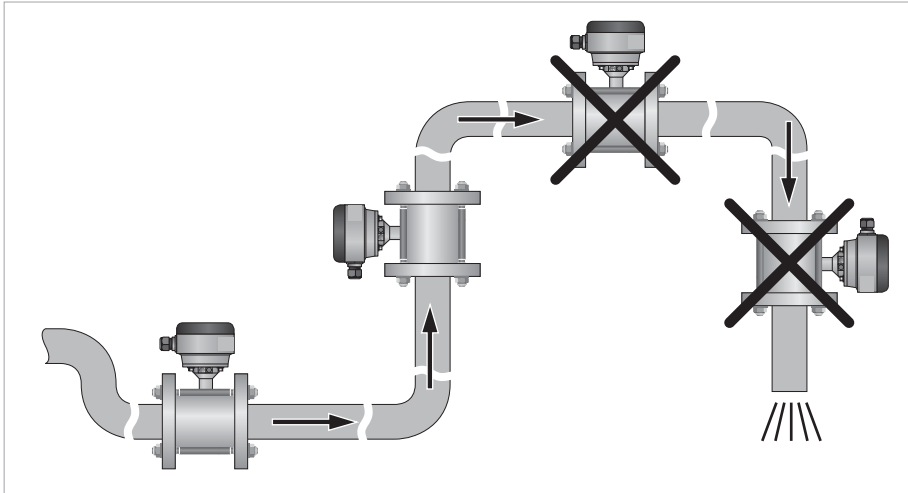

Figure 2-10: Installation in bending pipes

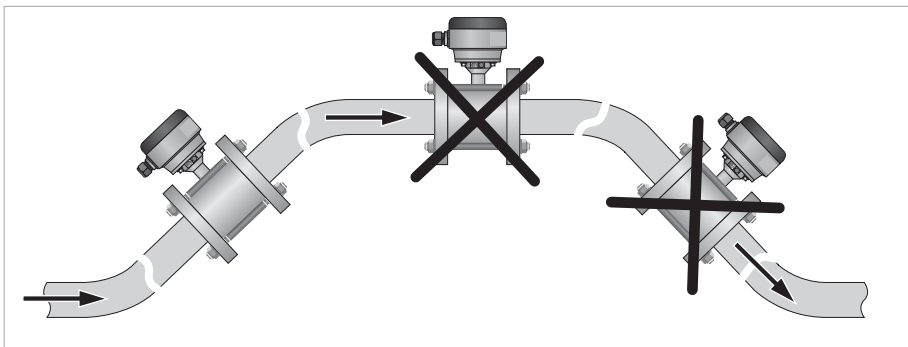

Figure 2-11: Installation in bending pipes



CAUTION!
 Avoid draining or partial filling of the flow sensor

2.8.5 Open feed or discharge

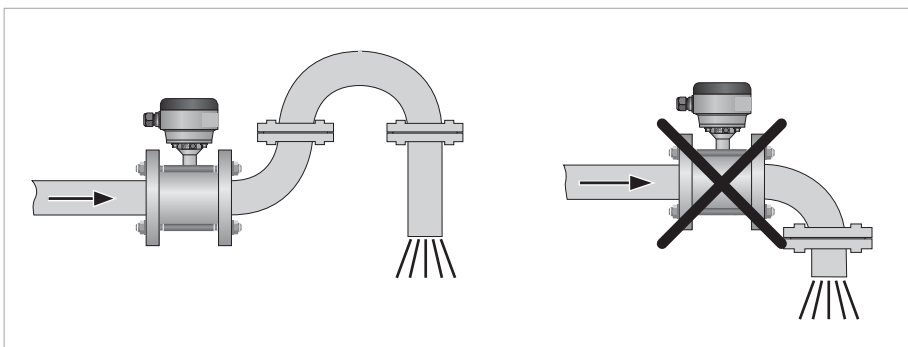

Figure 2-12: Installation in front of an open discharge

2.8.6 Flange deviation



CAUTION!

Max. permissible deviation of pipe flange faces:

$$L_{max} - L_{min} \leq 0.5 \text{ mm} / 0.02''$$

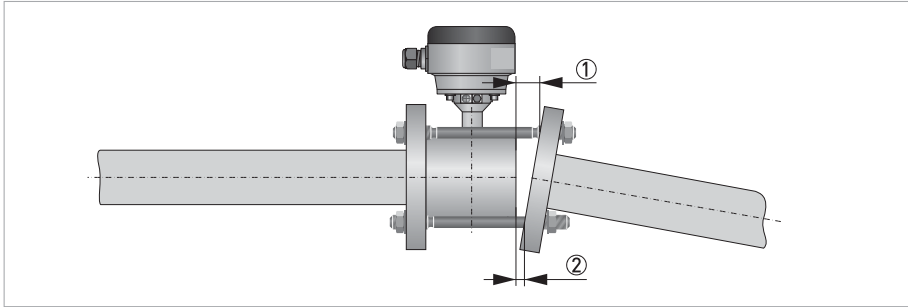

Figure 2-13: Flange deviation

- ① L_{max}
- ② L_{min}

2.8.7 Control valve

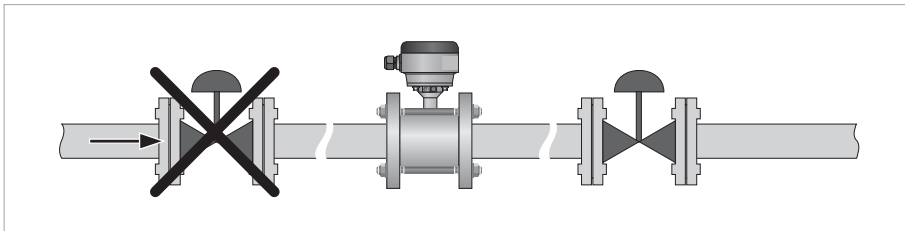

Figure 2-14: Installation in front of a control valve

2.8.8 Pump

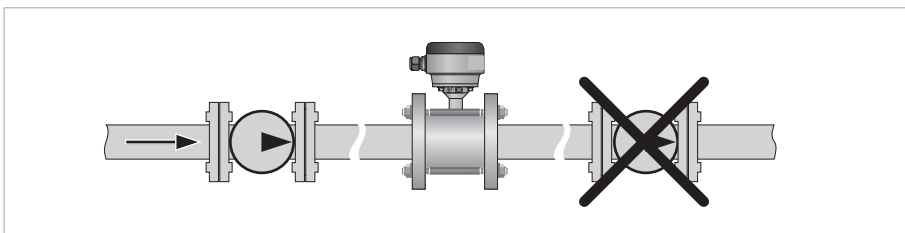

Figure 2-15: Installation behind a pump

2.8.9 Air venting and vacuum forces

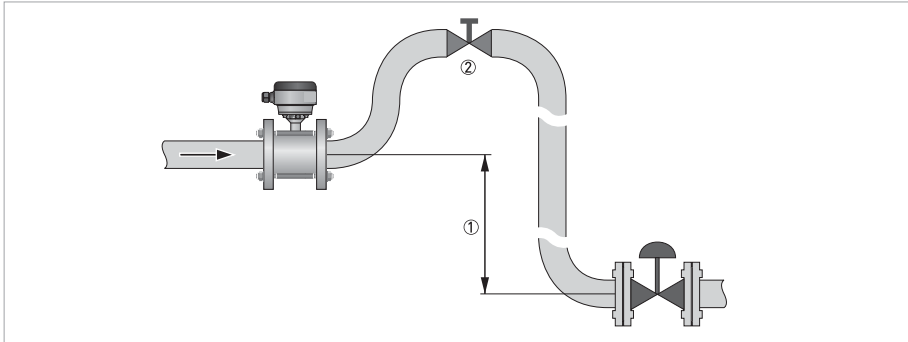

Figure 2-16: Air venting

- ① ≥ 5 m / 17 ft
- ② Air ventilation point

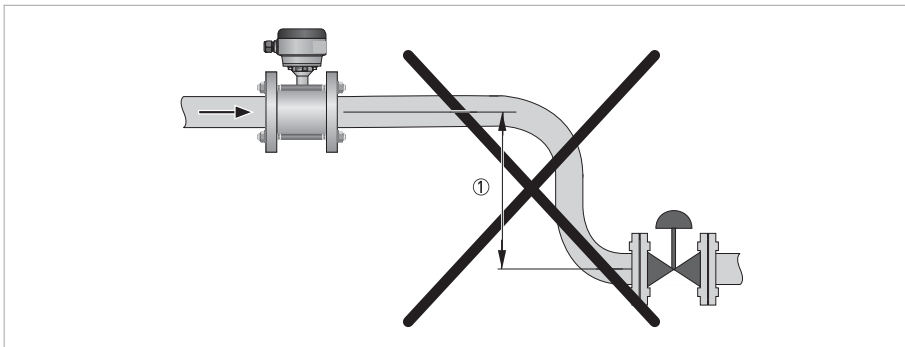

Figure 2-17: Vacuum

- ① ≥ 5 m / 17 ft

2.8.10 Mounting position

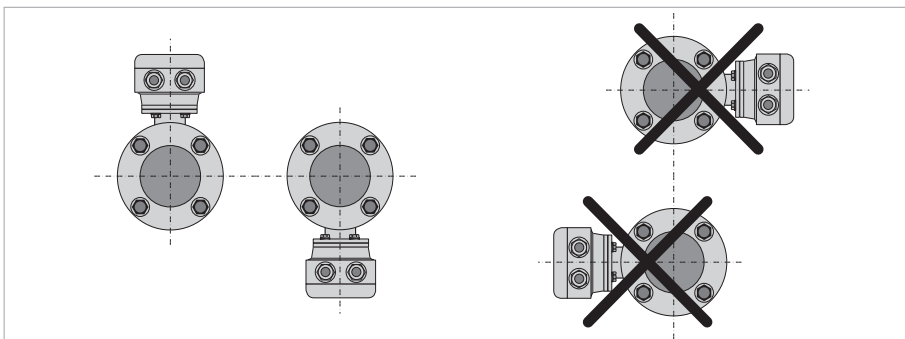

Figure 2-18: Mounting position

2.9 Mounting

2.9.1 Torques and pressures

The maximum pressure and torques values for the flowmeter are theoretical and calculated for optimum conditions and use with carbon steel flanges.

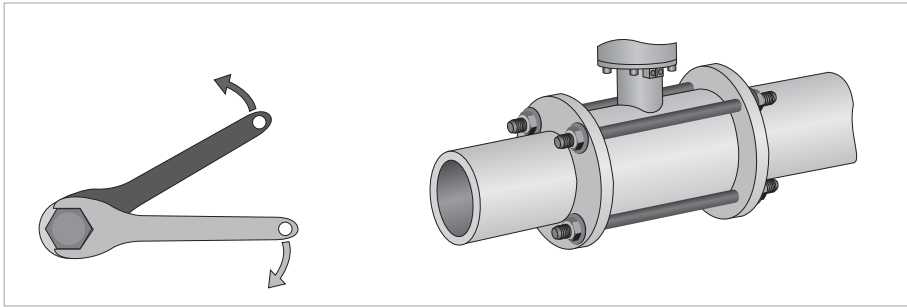

Figure 2-19: Tightening of bolts



Tightening of bolts

- Always tighten the bolts uniformly and in diagonally opposite sequence.
- Do not exceed the maximum torque value.
- Step 1: Apply approx. 50% of max. torque given in table.
- Step 2: Apply approx. 80% of max. torque given in table.
- Step 3: Apply 100% of max. torque given in table.

EN 1092-1

Nominal size DN [mm]	Counter flanges		Maximum operating pressure [bar]	Bolts	Max. torque [Nm] ②
	Flange size DN [mm]	Flange class [lb]			
10	15 ①	PN 16/40	≤16	4 x M12	16
15	15	PN 16/40	≤16	4 x M12	16
25	25	PN 16/40	≤16	4 x M12	16
40	40	PN 16/40	≤16	4 x M16	25
50	50	PN 16/40	≤16	4 x M16	45
80	80	PN 16/40	≤16	4 x M16	25
100	100	PN 16	≤16	8 x M16	33
100	100	PN 40	≤16	8 x M20	33
150	150	PN 16	≤16	8 x M20	82
150	150	PN 40	≤16	8 x M24	82

① For DN10 and 15 sizes use DN15 counter (pipe) flanges.

② The specified torque values are dependent on variables (temperature, bolt material, gasket material, lubricants, etc.) which are not within the control of the manufacturer. Therefore the values should be regarded as indicative only.

ASME B16.5

Nominal size DN [inch]	Counter flanges		Max. operating pressure [psig]	Bolts	Max. torque [lbs.ft] ②
	Flange size DN [inch]	Flange class [lb]			
3/8"	1/2" ①	150/300 lb	230	4 x 1/2"	11.6
1/2"	1/2"	150/300 lb	230	4 x 1/2"	11.6
1"	1"	150/300 lb	230	4 x 1/2"	10.8
1 1/2"	1 1/2"	150/300 lb	230	4 x 1/2"	18.1
2"	2"	150/300 lb	230	4 x 5/8"	32.5
3"	3"	150 lb	230	4 x 5/8"	40.5
3"	3"	300 lb	230	8 x 5/8"	20.5
4"	4"	150/300 lb	230	8 x 5/8"	26
6"	6"	150 lb	230	8 x 3/4"	72.3
6"	6"	300 lb	230	12 x 3/4"	47.7

① For DN3/8" and 1/2" use DN1/2" counter (pipe) flanges.

② The specified torque values are dependent on variables (temperature, bolt material, gasket material, lubricants, etc.) which are not within the control of the manufacturer. Therefore the values should be regarded as indicative only.

**CAUTION!**

- Pressures are applicable at 20° C / 68° F.
- For higher temperatures, the pressure ratings are as per ASME B16.5.

3.1 Safety instructions



DANGER!

All work on the electrical connections may only be carried out with the power disconnected. Take note of the voltage data on the nameplate!



DANGER!

Observe the national regulations for electrical installations!



WARNING!

Observe without fail the local occupational health and safety regulations. Any work done on the electrical components of the measuring device may only be carried out by properly trained specialists.



INFORMATION!

Look at the device nameplate to ensure that the device is delivered according to your order. Check for the correct supply voltage printed on the nameplate.

3.2 Grounding



DANGER!

The device must be grounded in accordance with regulations in order to protect personnel against electric shocks.

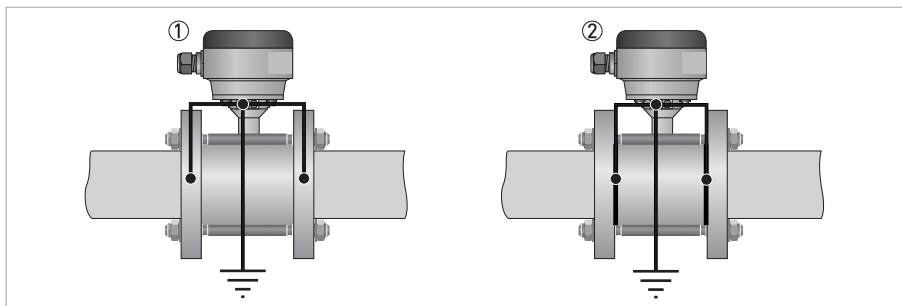

Figure 3-1: Grounding

- ① Metal pipelines, not internally coated. Grounding without grounding rings!
- ② Metal pipelines with internal coating and non-conductive pipelines. Grounding with grounding rings!

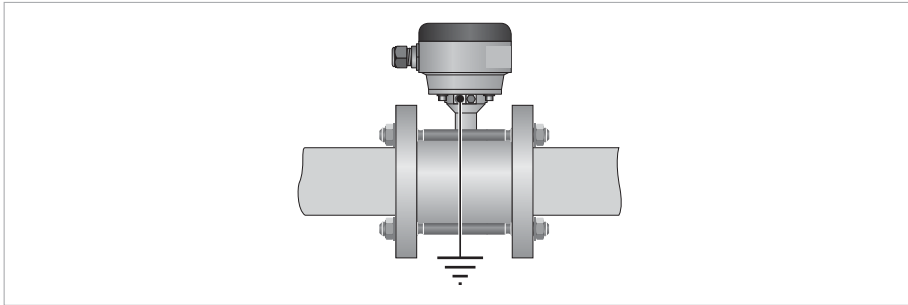

Figure 3-2: Build-in grounding rings for DN10-15 / 3/8 - 1/2"



INFORMATION!

For diameter DN10 / 3/8" and DN15 / 1/2", grounding rings are integrated as standard in the flow sensor construction.

Grounding rings



Figure 3-3: Grounding ring number 1

Grounding ring number 1 (optional for DN25...150 / 1...6"): Thickness: 3 mm / 0.1"

3.3 Virtual reference for TWM 9000

The virtual reference option on the TWM 9000 flow converter provides complete isolation of the measurement circuit.

Benefits of virtual reference:

- Grounding rings or grounding electrodes can be omitted.
- Safety increases by reducing the number of potential leakage points.
- The installation of the flowmeters is much easier.

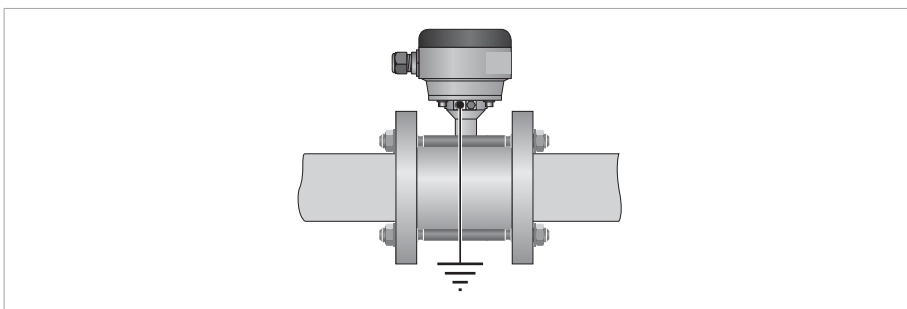

Figure 3-4: Virtuele referentie

Minimum requirements:

- Size: \geq DN10 / 3/8"
- Electrical conductivity: \geq 200 μ S/cm
- Electrode cable: max. 50 m / 164 ft, type DS

3.4 Connection diagrams



INFORMATION!

For the connection diagrams please refer to the documentation of the applicable signal converter.

4.1 Dimensions and weights

<p>Remote version: DN10...40 / 3/8...1½"</p>		<p>a = 88 mm / 3.5" b = 139 mm / 5.5" ① c = 106 mm / 4.2" Total height = H + a</p>
<p>Remote version: DN50...150" / 2...6"</p>		<p>a = 88 mm / 3.5" b = 139 mm / 5.5" ① c = 106 mm / 4.2" Total height = H + a</p>
<p>Compact version with TWM 9000</p>		<p>a = 155 mm / 6.1" b = 230 mm / 9.1" ① c = 260 mm / 10.2" Total height = H + a</p>
<p>Compact version with TWM 1000 (0°)</p>		<p>a = 82 mm / 3.2" b = 161 mm / 6.3" c = 257 mm / 10.1" ① Total height = H + a</p>
<p>Compact version with TWM 1000 (45°)</p>		<p>a = 186 mm / 7.3" b = 161 mm / 6.3" c = 184 mm / 7.3" ① Total height = H + a</p>

① The value may vary depending on the used cable glands.



INFORMATION!

- All data given in the following tables are based on standard versions of the flow sensor only.
- Especially for smaller nominal sizes of the flow sensor, the signal converter can be bigger than the flow sensor.
- Note that for other pressure ratings than mentioned, the dimensions may be different.
- For full information on signal converter dimensions see relevant documentation.

EN 1092-1

Nominal size	Dimensions [mm]			Approx. weight [kg]
DN	L	H	W	
10	68	137	47	1.7
15	68	137	47	1.7
25	54	147	66	1.7
40	78	162	82	2.6
50	100	151	101	4.2
80	150	180	130	5.7
100	200	207	156	10.5
150	200	271	219	15.0

ASME B16.5

Nominal size	Dimensions [inch]			Approx. weight [lb]
ASME	L	H	W	
3/8"	2.68	5.39	1.85	3.7
1/2"	2.68	5.39	1.85	3.7
1"	2.13	5.79	2.6	3.7
1 1/2"	3.07	6.38	3.23	5.7
2"	3.94	5.94	3.98	9.3
3"	5.91	7.08	5.12	12.6
4"	7.87	8.15	6.14	23.1
6"	7.87	10.67	8.62	33.1

Honeywell Process Solutions
1250 W Sam Houston Pkwy S
Houston, TX 77042
www.honeywellprocess.com

© Honeywell International Inc.
Subject to change without notice.