



TEK-TEMP 2100A

Explosion-Proof Temperature Transmitter

Instruction Manual

Document Number: IM-2100A

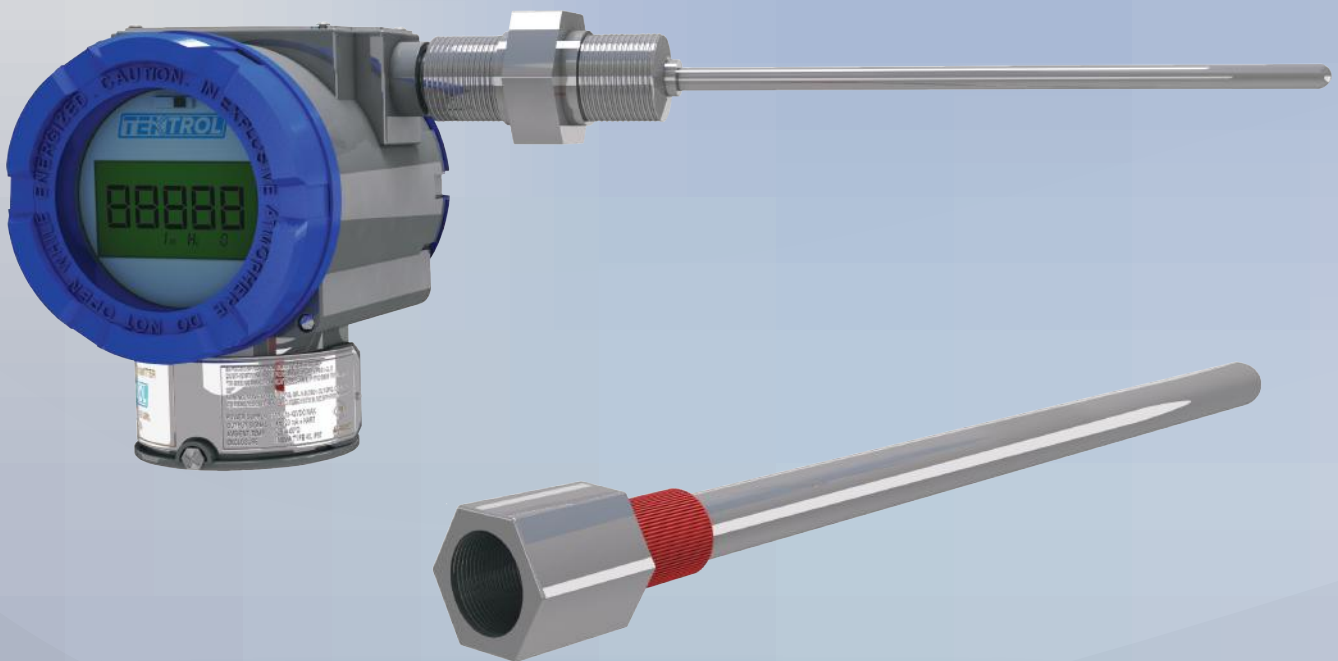

www.tek-trol.com

NOTICE

Read this manual before working with the product. For personal and system safety, and for optimum product performance, make sure you thoroughly understand the contents before installing, using, or maintaining this product.

For technical assistance, contact

Customer Support

796 Tek-Drive

Crystal Lake, IL 60014

USA

Tel: +1 847 857 6076, +1 847 655 7428

© **COPYRIGHT Tek-Trol LLC 2016**

No part of this publication may be copied or distributed, transmitted, transcribed, stored in a retrieval system, or translated into any human or computer language, in any form or by any means, electronic, mechanical, manual, or otherwise, or disclosed to third parties without the express written permission. The information contained in this manual is subject to change without notice.

Table of Contents

1	Safety Instructions	3
1.1	Intended Use	3
1.2	Certification.....	3
1.3	Safety Instructions from the Manufacturer	3
1.3.1	Disclaimer	3
1.3.2	Product Liability and Warranty	3
1.3.3	Information Concerning the Documentation.....	3
1.4	Safety Precautions	4
1.4.1	Warnings and Symbols Used	4
1.5	Packaging, Transportation and Storage.....	5
1.5.1	Packaging.....	5
1.5.2	Transportation.....	5
1.5.3	Storage	5
1.5.4	Nameplate.....	6
2	Product Description	7
2.1	Introduction	7
2.2	Measuring Principle	7
2.3	Specifications.....	8
2.3.1	Temperature Sensor Range and Accuracy	8
2.3.2	Electrical Specifications.....	9
2.3.3	Performance Specifications.....	9
2.3.4	Physical Specifications.....	9
2.4	Exploded View	10
2.5	Dimensional Drawing.....	11
2.6	Model Chart.....	11
3	Installation	12
3.1	Selection of Installation of Locations	13
3.2	Waterproofing of Cable Conduit Connections	13
3.3	Restriction on Use of Radio Transceivers	13
3.4	Insulation Resistance Test or Dielectric Strength Test.....	14
3.5	Mounting.....	15
3.6	Consideration of Transmitter Access.....	15
4	Electrical Connections	16
4.1	General Considerations	16
4.2	Electrical Considerations	16
4.3	Connection of Sensor	17
4.4	Power Supply Information	17
4.4.1	Selection of Wiring Materials.....	18
4.4.2	Connection of External Wiring to Transmitter Terminal Box.....	18
4.5	Loop Configuration	19
4.6	Wiring Installation	21
4.7	Grounding	23
4.8	Power Supply and Load Resistance	23

4.9	Environmental Considerations	24
4.9.1	Effect of Ambient Temperature	24
4.9.2	Environment Having Toxic Material/ Moisture.....	24
4.9.3	Installation in a Dangerous Place	24
5	Operation	25
5.1	LCD Display	25
5.2	LCD Screen Rotation	25
5.3	Fail Mode Alarm	26
5.4	EEPROM-Write Enable/ Disable Mode Switch	27
5.4.1	Security Jumper (EEPROM-Write Protect)	28
5.4.2	Zero and Span Magnetic Button	28
5.5	Configuration of Alarm and Security Jumper Procedures	28
5.6	Configuration of Zero and Span Procedures	28
5.7	Configuration of Zero Point Adjustment	29
5.8	Shop Commissioning using HHT	30
5.9	Commissioning on the Bench with a Hand-Held Terminal	31
5.10	Description of LCD Messages	33
5.11	On-line Operations	35
5.11.1	Configuration of Current to Passive Mode	36
5.11.2	Configuring Data Review.....	36
5.11.3	Check Output	36
5.11.4	Basic Setup.....	36
5.11.5	Detailed Setup.....	37
5.11.6	Configuration of Information Variable	37
5.11.7	Configuration of Breakdown Diagnostic Function	37
5.11.8	Calibration.....	38
5.12	Menu Tree	39
6	Maintenance	40
6.1	Hardware Diagnostics	40
6.2	Hardware Maintenance	42
6.2.1	Test Terminals	42
6.2.2	Disassembling of Electronics Housing	43
6.2.3	Assembling the Electronics Structure	44
7	Appendix	46

1 Safety Instructions

1.1 Intended Use

Tek-Temp 2100A is a temperature field transmitter for Resistance Temperature Detectors (RTD), Thermocouple (TC), as well as resistance and voltage sensors. The unit is specifically used for mounting in field applications.

1.2 Certification

Tek-Temp 2100A has CE and FM certifications

1.3 Safety Instructions from the Manufacturer

1.3.1 Disclaimer

The manufacturer will not be accountable for any damage by using its product, including, but not limited to direct, indirect or incidental and consequential damages. Any product purchased from the manufacturer is warranted in accordance with the relevant product documentation and our Terms and Conditions of Sale.

The manufacturer has the right to modify the content of this document, including disclaimer, at any time for any reason without prior notice and will not be answerable in any way for the possible consequence of such changes.

1.3.2 Product Liability and Warranty

The operator shall bear authority for the suitability of the device for the specific application. The manufacturer accepts no liability for the consequences of misuse by the operator. Wrong installation or operation of the devices (systems) will cause the warranty to be void. The respective "Standard Terms and Conditions", which forms the basis for the sales contract shall also apply.

1.3.3 Information Concerning the Documentation

To prevent any injury to the operator and damage to the device it is essential to read the information in this document and read the applicable national standard, and safety instruction.

These operating instructions contain all the information that is required in various stages, like product identification, incoming acceptance and storage, to mounting, connection, operation and commissioning through to troubleshooting, maintenance and disposal.

1.4 Safety Precautions

You must read these instructions carefully prior to installing and commissioning the device. These instructions are an important part of the products and must be kept for further reference. For additional information or if specific problems occur that are not discussed in these instructions, contact the manufacturer.

Only by observing these instructions can optimum protection of both personnel and the environmental, as well as safe and fault-free operation of the device be ensured.

1.4.1 Warnings and Symbols Used

The following safety symbol marks are used in this operating instruction manual and instrument.



WARNING

A warning highlights actions or procedures which, if not performed correctly, will lead to personal injury, a safety hazard or destruction of the instrument



CAUTION

Caution highlight actions or procedures which, if not performed correctly, may lead to personnel injury, safety hazard or destruction of the instrument



NOTE

“Note” indicates an action or procedure which, if not performed correctly, can have an indirect effect on operation or trigger an unexpected response on the part of the device

1.5 Packaging, Transportation and Storage

1.5.1 Packaging

- Tek-Temp 2100A Explosion-proof Temperature Transmitter
- Documentation



1.5.2 Transportation

- When the transmitter is delivered, visually check them to make sure that no damage occurred during shipment
- To avoid any damages, unpack the flowmeter only at the installation site
- Avoid impact shocks, rain and water during transportation
- Do not throw or drop the device
- Use original packaging for transport and ensure that the packaging does not get crushed or damaged by sharp objects or other boxes
- The flow tube is shipped with end covers to protect it from mechanical damage and normal unrestrained distortion. End covers should not be removed until just before installation
- Keep shipping plugs in conduit connections until conduits are connected and sealed

1.5.3 Storage

The following precautions must be observed when storing the instrument, especially for a long period:

- Select a storage area that meets the following conditions:
 1. It is not exposed to rain or water
 2. It suffers minimum vibration and shock
 3. If possible, it is preferable at normal temperature and humidity (approx. 77°F (25°C), 65% RH) is preferable
- The ambient temperature limit should be:
 1. Without LCD Module: -45°F to 185°F (-40°C to 85°C)
 2. With LCD Module: -22°F to 176°F (-30°C to 80°C)
- The relative humidity should be: 5% to 98% RH at 104°F (40°C)
- When storing the transmitter, repack it in a similar way as it was packed when delivered from the factory
- Make sure before storing that the sensor module, flange, and housing is securely mounted

1.5.4 Nameplate



NOTE

Look at the device nameplate to ensure that the device is delivered according to your order. Check for the correct supply voltage printed on the nameplate

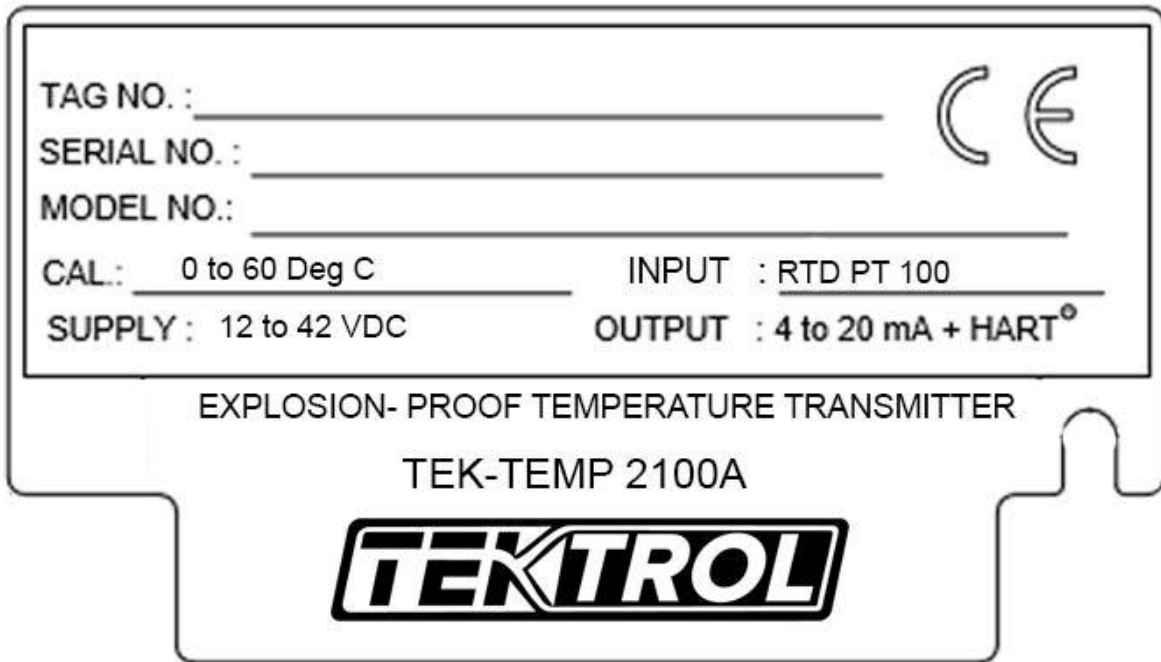

2 Product Description

2.1 Introduction

Tek-Trol's Explosion-proof Temperature Transmitter is a microprocessor based temperature transmitter that has temperature sensors such as Thermocouple, RTD, mV, and Resistance. The Tek-Temp 2100A is explosion-proof type and has high precision, better reliability and uses a remote communication system. This transmitter is enabled in HART communication with Host, a HHT (HART Hand-Held Terminal), or PC Configurator. The transmitter has a number of variables in host that can be changed, configured, and calibrated by users with the help of HHT.

2.2 Measuring Principle

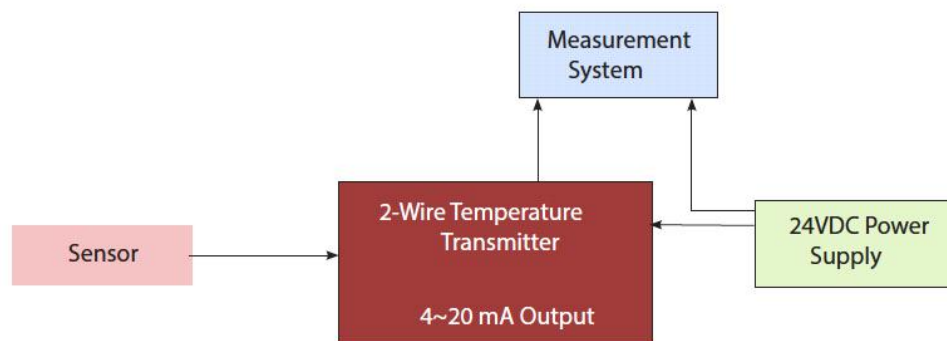

A temperature transmitter is typically connected to a 24VDC power source. The temperature sensor such as RTD or Thermocouple measures the temperature of the medium. The transmitter first modifies the output signal of the sensor into a standard format with the help of Signal Conditioning process such as Amplification, Isolation, Filtering, Linearization, and Excitation. The transmitter amplifies and converts the output to a high-level analog signal, usually a standard 4-20mA signal. It then transmits the amplified signal to the control device by means of long cable runs.

2.3 Specifications

2.3.1 Temperature Sensor Range and Accuracy

Table 1

Sensor Type	Sensor Reference	Input Range	Minimum Span	Digital Accuracy	D/A Accuracy of Span
RTD					
Pt-100	KSC 1603-1991 (a=0.00385) DIN	-328-1202°F (-200-650°C)	59°F (15°C)	±32.3°F (±0.17°C)	±0.03%
Pt-100	JISC 1604-1981 (a=0.00391)	-328-1202°F (-200-650°C)		±32.3°F (±0.16°C)	
Thermocouple					
NIST Type B	KSC1602-1982	212-3308°F (100 - 1,820 °C)	482°F (250 °C)	±33.38°F (±0.77°C)	±0.03%
NIST Type E		-328-1832°F (-200 - 1,000°C)		±32.36°F (±0.20°C)	
NIST Type J		392-2192°F (200 - 1,200°C)		±32.45°F (±0.25°C)	
NIST Type K		-328-2462°F (-200 - 1,350°C)		±32.63°F (±0.35°C)	
NIST Type N		392-2372°F (200 - 1,300°C)		±32.72°F (±0.40°C)	
NIST Type R		32-3200°F (0 - 1,760°C)		±33.08°F (±0.60°C)	
NIST Type S		32-3164°F (0 - 1,740°C)		±32.9°F (±0.50°C)	
NIST Type T		-328-752°F (-200 - 400°C)		±32.45°F (±0.25°C)	
Millivolt Input		-10 - 75mV	2mV	± 0.012mV	
Ohm Input		0 - 340Ω	20Ω	± 0.3 Ω	

NOTE:

- 1) RTD input: a=0.00385: KS, JIS, DIN, IEC; a=0.0039: US
- 2) Thermocouple input: KSC 1602-1982, JISC 1602-1981, ANSI MC96.1-1982
- 3) Digital accuracy for Type B is ±37.4°F (± 3.0°C) from 212°F to 572°F (100 to 300°C)
- 4) Digital accuracy for Type K is ±32.9°F (±0.50°C) from -292°F to -130°F (-180 to -90°C)

Table 2

Ambient Temperature Effects [per 33.8⁰F (1⁰C) Change in Ambient Temperature]			
	Sensor Type	Digital Accuracy	D/A Effect Per
RTD 2w, 3w, 4-Wire	Pt 100 (a=0.00385)	32 ⁰ F	0.002% of Span
	Pt 100 (a=0.003916)	(0.003 ⁰ C)	
Thermocouple	NIST Type B	32.08 ⁰ F (0.046 ⁰ C)	
	NIST Type E, J, K, N	32 ⁰ F (0.005 ⁰ C) +0.00054% of reading	
	NIST Type R, S, T	32.02 ⁰ F (0.015 ⁰ C) If reading ≥ 392 ⁰ F (200 ⁰ C) 32.03 ⁰ F (0.021 ⁰ C) - 0.0032% of reading if not	

2.3.2 Electrical Specifications

Power Supply	Output Signal	HART Loop Resistance	Isolation
Voltage Range: 12 to 45 VDC Voltage Rating: 24 VDC ±30%	4 to 20 mA DC/HART	250 to 550 ohm (24 VDC)	500 Vrms (707 VDC)

2.3.3 Performance Specifications

Accuracy	Refer Table 1	Operating Temperature	-40 ⁰ F to 185 ⁰ F (-40 ⁰ C to 85 ⁰ C)
Stability for 2 Years	±0.1% of Reading or 32.18 ⁰ F (0.10 ⁰ C) whichever is greater	LCD Meter Operating Temperature	-22 ⁰ F to 176 ⁰ F (-30 ⁰ C to 80 ⁰ C)
Ambient Temperature Effect	±0.05% of Span/50 ⁰ F (10 ⁰ C)	Humidity Limits	5% to 100% RH
Repeatability	±0.05% of Span	Power Supply Effect	±0.005% of Span/V

2.3.4 Physical Specifications

Electrical Connections	½" to 14" NPT	Weight	2.64lb (1.2kg)
Electronics Housing	Aluminum	Housing Class	Waterproof (IP67)
O-rings	BUNA-N		

2.4 Exploded View

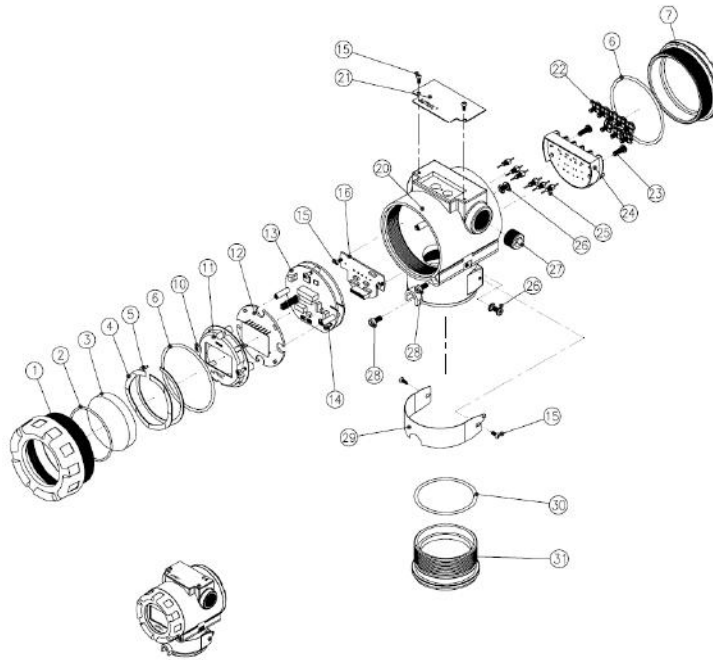

P.N	PART NAME	P.N	PART NAME
1	FRONT COVER	20	HOUSING
2	O-RING/GLASS	21	NAMEPLATE
3	GLASS	22	TERMINAL SCREW
4	WAVE WASHER	23	SCREW/TERMINAL BLOCK
5	C-SNAP RING	24	TERMINAL BLOCK
6	O-RING/COVER	25	EMI FILTER
7	REAR COVER	26	SCREW
10	SCREW/LCD	27	PIPE PLUG
11	LCD COVER	28	SCREW
12	LCD BOARD	29	TAGPLATE
13	MAIN BOARD	30	O-RING/SENSOR MODULE
14	SCREW/MAIN BOARD	31	SENSOR MODULE BOTTOM
15	SCREW		
16	TERMINAL BOARD		

2.5 Dimensional Drawing

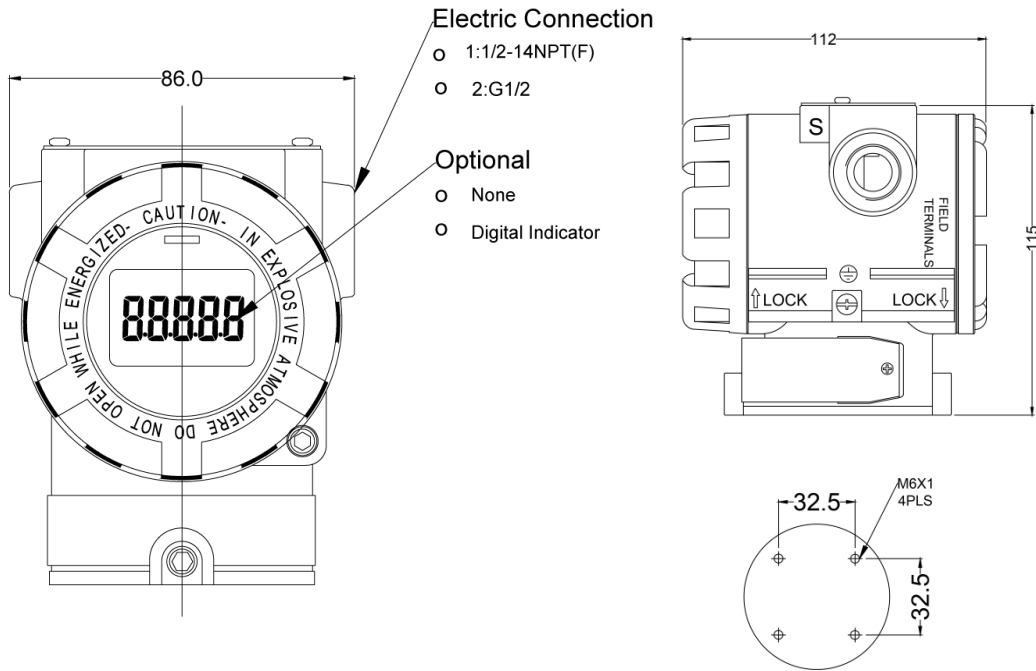

2.6 Model Chart

Example	Tek-Temp 2100A	S	1	FM	LCD	Tek-Temp 2100A-S-1-FM-LCD
Series	Tek-Temp 2100A					Explosion-proof Temperature Transmitter
Sensor Elements		S				Single Element
Housing and Electrical Connection			1			1/2" to 14" NPT, Epoxy Coated Aluminum
Hazardous Location Certificates				FM		FM/FMc Explosion-proof (Class I/II/III, Div. 1/2, Group A-D/E-G)
Options						M0 Blind Unit LCD LCD Display FC Factory Calibration, No Certificate TAG Stainless Steel Tag CC3 Custom Range, 3 point Cal Cert

3 Installation



CAUTION

- Installation of the device must be carried out by trained, qualified specialists authorized to perform such work by the facility's owner operator. The specialist must have read and understood these Operating Instructions and must follow the instructions they contain
 - When removing the instrument from hazardous processes, avoid contact with the fluid and the interior of the meter
 - All installation shall comply with local installation requirement and local electrical code
 - When the following notes are not observed, flow measurements may not be correct and can damage the instrument. Please make correct piping design in accordance with the present guidelines.
-



WARNING

- This section offers instructions for installation, wiring, operation, and troubleshooting. The user must read this manual carefully before installation and operation, because improper installation may cause incorrect measurement and even damage the flowmeter.
-



NOTE

Improper installation has the potential to cause injury and to damage instrument. Periodically inspect the power cables, transducer cables, cable glands and the enclosure for signs of damage. Inspect transducer installation and mounting hardware for loose connections.

3.1 Selection of Installation of Locations

The transmitter is designed to withstand severe environmental conditions. However, to ensure stable and accurate operation for many years, the following precautions must be observed when selecting an installation location:

- **Ambient Temperature**
Avoid locations subject to wide temperature variations or a significant temperature gradient. If the location is exposed to radiant heat from plant equipment, provide adequate insulation or ventilation
- **Ambient Atmosphere**
Avoid installing the transmitter in a corrosive atmosphere. If the transmitter must be installed in a corrosive atmosphere, there must be adequate ventilation as well as measures should be taken to prevent intrusion or stagnation of rainwater in conduits. Moreover, there should be appropriate ventilation preventing corrosion by rain gathered on conduit
- **Shock and Vibration**
Select an installation site that experiences minimum shock and vibration (although the transmitter is designed to be relatively resistant to shock and vibration).
- **Installation of Explosion-Protected Transmitters**
Explosion-protected transmitters can be installed in hazardous areas according to the gas types for which they are certified.
- Select a location where the maintenance of transmitter can be conducted easily.

3.2 Waterproofing of Cable Conduit Connections

Apply a non-hardening sealant (silicone or tape, etc.) to the threads to waterproof the transmitter cable conduit connections.

3.3 Restriction on Use of Radio Transceivers

Although the transmitter has been designed to resist high frequency electrical noise, if a radio transceiver is used near the transmitter or its external wiring, the transmitter may be affected by high frequency noise pickup. To test for such effects, bring the transceiver in use slowly from a distance of several meters from the transmitter, and observe the measurement loop for noise effects. Thereafter, always use the transceiver outside the area affected by noise.

3.4 Insulation Resistance Test or Dielectric Strength Test

Since the transmitter has undergone insulation resistance and dielectric strength tests at the factory before shipment, normally these tests are not required. However, if required, observe the following precautions in the test procedures:

- Do not perform such tests unless it is absolutely necessary. Even test voltages that do not cause visible damage to the insulation may degrade the insulation and reduce safety margins.
- Never apply a voltage exceeding 500 VDC (100 VDC with an internal lightning protector) for the insulation resistance test, or a voltage exceeding 500VAC (100VAC with an internal lightning protector) for the dielectric strength test.
- Before conducting these tests, disconnect all signal lines from the transmitter terminals. Perform the tests according to the following procedure.
- Insulation Resistance Test
 1. Short-circuit the +ve and -ve SUPPLY terminals in the terminal box.
 2. Turn OFF the insulation tester. Then connect the insulation tester plus (+) lead wire to the shorted SUPPLY terminals and the minus (-) lead wire to the GRONDING terminal.
 3. Turn ON the insulation tester power and measure the insulation resistance. The voltage should be applied should be as short as possible to verify that insulation resistance is at least 20MΩ.
 4. After completing the test and being very careful not to touch exposed conductors, disconnect the insulation tester and connect a 100kW resistor between the grounding terminal and the short-circuiting SUPPLY terminals. Leave this resistor connected for at least 3-seconds to discharge any static potential. Do not touch the terminal while it is discharging.
- Dielectric Strength Test
 1. Short-circuit the +ve and -ve SUPPLY terminals in the terminal box.
 2. Turn OFF the dielectric strength tester. Then connect the tester between the shorted SUPPLY terminal and the GROUNDING terminal. Be sure to connect the grounding lead of the dielectric strength tester to the ground terminal.
 3. Set the current limit on the dielectric strength tester to 10mA, then turn ON the power and gradually increase the tester voltage from '0' to the specified voltage.
 4. When the specified voltage is reached, hold it for 1-minute.
 5. After completing this test, slowly decrease the voltage to avoid any voltage surges.

3.5 Mounting

To use the cadence carrier from the environment where the vibration is heavy and must install the transmitter: In the environment where the vibration is heavy you will have to install the transmitter by using an assistant support. In the case of severe vibration, promote to mount-on pipe using a mounting bracket.

The Tek-Temp 2100A Temperature Transmitter can be mounted in 2 ways:

- Remote mounting sensor
- Direct mounting sensor

It is possible to install temperature sensor on both.

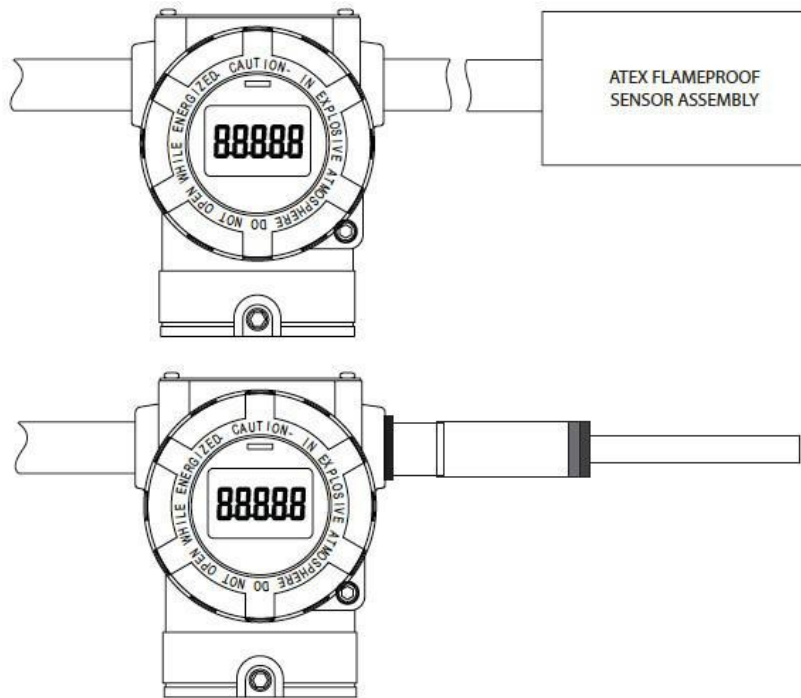

3.6 Consideration of Transmitter Access

When selecting the establishment location for the transmitter, to treat a location is convenient you must consider:

- Rotation of housing: housing can be rotated up to 90°
- Terminal sides of transmitter: Use terminal space where can easily pull out the transmitter cover
- Circuits side of transmitter: the space where there is a possibility of treating an electronic circuit / the space where you can easily be able to pull out the transmitter cover. If an LCD meter is installed, it requires extra space

4 Electrical Connections



WARNING

Explosion can result in death or serious injury.

- Do not remove the transmitter covers in explosive environments when the circuit is alive
 - In an explosive environment, check the transmitter is installed according to safety regulations before connecting the HHT to the transmitter
 - Transmitter covers must be fully engaged to meet explosion-proof requirements
 - Only a suitable trained and qualified person must establish the transmitter
 - Avoid contact with the leads and terminals. High voltage that may be present on leads and can cause electrical shock
-

4.1 General Considerations

This transmitter uses temperature sensors. It transfers electrical signal minutely to 4 to 20mA analog signal. Thus, mount the transmitter close to the process and use a minimum of sensor length to achieve best accuracy. However, keep in mind the need for easy access, safety of personnel, practical field calibration, and a suitable transmitter environment. In general, install the transmitter so as to minimize vibration, shock, and temperature fluctuations.

4.2 Electrical Considerations

The transmitter housing composes of two parts. One side is electronics circuit, and other side is terminal block. The terminal block side is the transmitter's front side and is indicated as "Field Terminal" in transmitter's external housing. Open this side's housing cover; the terminal block in-housing is inside. Consider the terminal block polarity while connecting the transmitter's power supply.

4.3 Connection of Sensor

The Tek-Temp 2100A Temperature Transmitter can input sensors such as RTD, Thermocouple (TC) and Resistance. In case RTD, 2Wire/3Wire and 4Wire Sensor connections are applicable. 2-Wire Thermocouple (B, E, J, K, N, R, S, T) sensor input can also be connected. The figure shown below indicates the connection of the sensor to the transmitter.

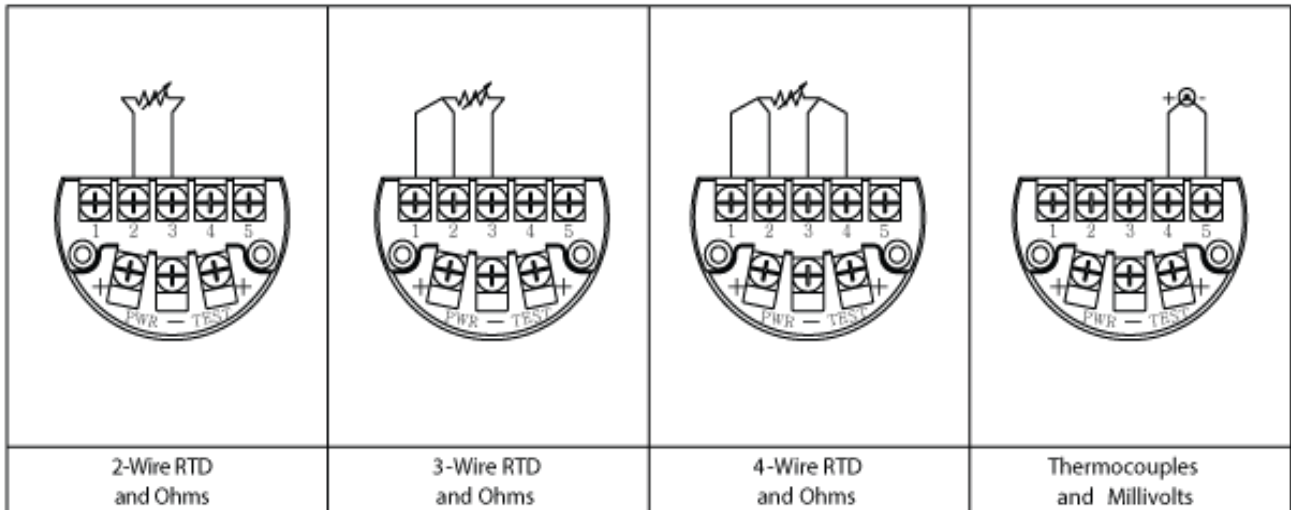

4.4 Power Supply Information

In the transmitter's power supply, input current voltage is between 11.9VDC to 45VDC and the ripple is not up to 2%. The loop resistance is preferable between 250Ω to 600Ω for the HART communication.



CAUTION

- Install cable far from electrical noise resources like capacitive transformers, motors and power supply as soon as possible
- Before wiring, remove electrical lead connect cap
- All screw-lined portions should be sutured to be waterproofed
- The power line and signal line should not be in the same duct, so as to avoid noise generation
- The explosion-proof transmitter should, in order to maintain the explosion-proof quality of the transmitter effectively, follow the explosion-proof specification that is provided

4.4.1 Selection of Wiring Materials

- Use over 600V PVC shielded wire or standard lead line of same class or cable. (In order to ensure proper communication use 24 AWG or larger wire, and do not exceed 4922 ft. (59064 ft)
- Use the shielded wire in electrical noise effected area
- At the area where temperatures are higher or lower than the ambient temperature, use the wire or the cable that is suitable for that specific temperature
- Use suitable wire or cable in environment with oil, solvent, toxic gas or liquid

4.4.2 Connection of External Wiring to Transmitter Terminal Box

- Open the housing cover indicated "FIELD TERMINAL". In explosive environments, when the circuit is powered on, DO NOT open the covers
- Connect the power supply in the terminal indicated "+PWR" (left terminal) and "-" power supply in the central terminal. Don't connect "+" power supply in "+" terminal of the point indicated "TEST". It will damage the test diode that is used.
- Seal and close the non-used conduit connection part to protect it from severe humidity and explosion in the terminal box of housing
- For a better adjustment, completely turn screw terminal
- Again. close the transmitter cover. Especially when using in an explosive area, you must to satisfy all safety requirements
- Do not supply a high voltage (AC power) in transmitter leads. It can cause damage to the transmitter
- You must connect a 250 – 600 ohm loop resistor in the current loop

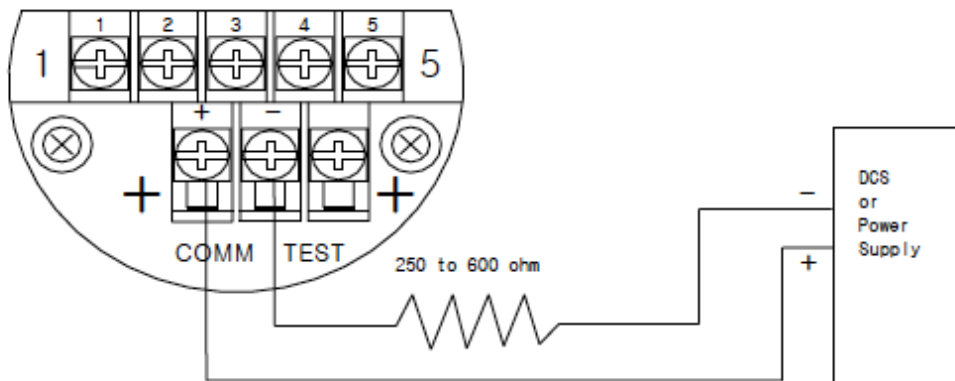

Connection of Current Loop

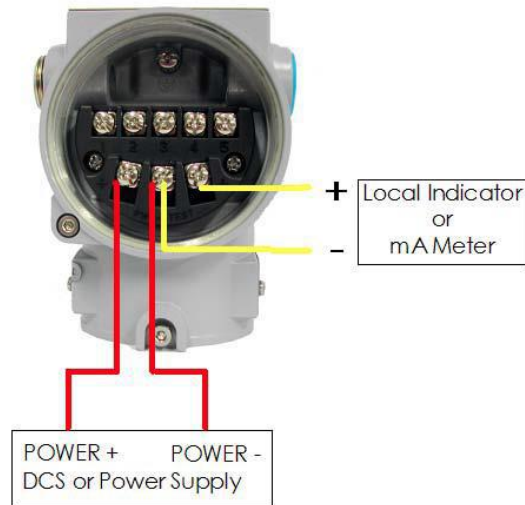

WARNING

Explosion can result in death or serious injury.

- Do not remove the transmitter covers in explosive environments when the circuit is alive
- In an explosive environment, check the transmitter is installed according to safety regulations, before the HHT is connected to the transmitter
- Transmitter covers must be fully engaged to meet explosion-proof requirements
- Only a suitably trained and qualified person must establish the transmitter
- Avoid contact with the leads and terminals. High voltage that may be present on leads can cause electric shock

4.5 Loop Configuration

Tek-Temp 2100A Transmitters use a two-wire system for power supply, 4 - 20mA analog signal transmission and HART digital transmission.

DC Power Supply is required for the transmitter loop. The transmitter and distributor are connected as shown below:

- In Non-Hazardous Locations

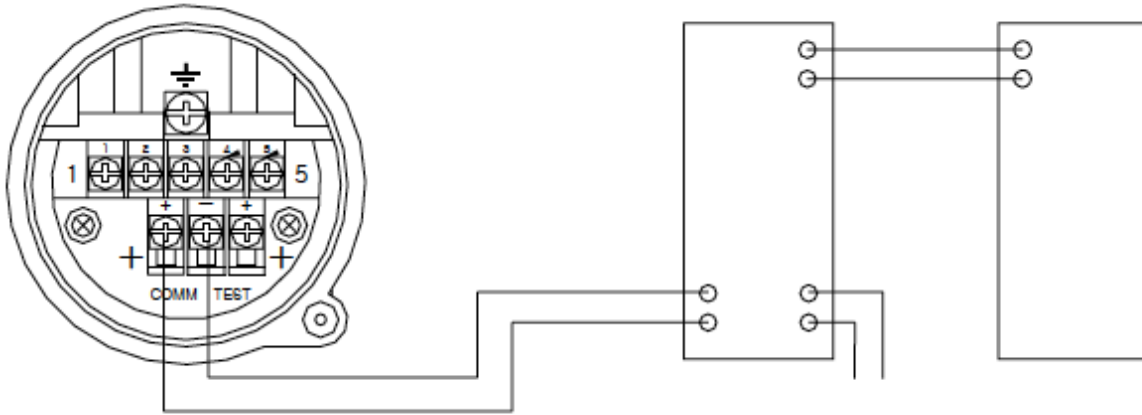

Transmitter Terminal Box

Power Supply Unit

Receiver Instrument

- In Hazardous Locations

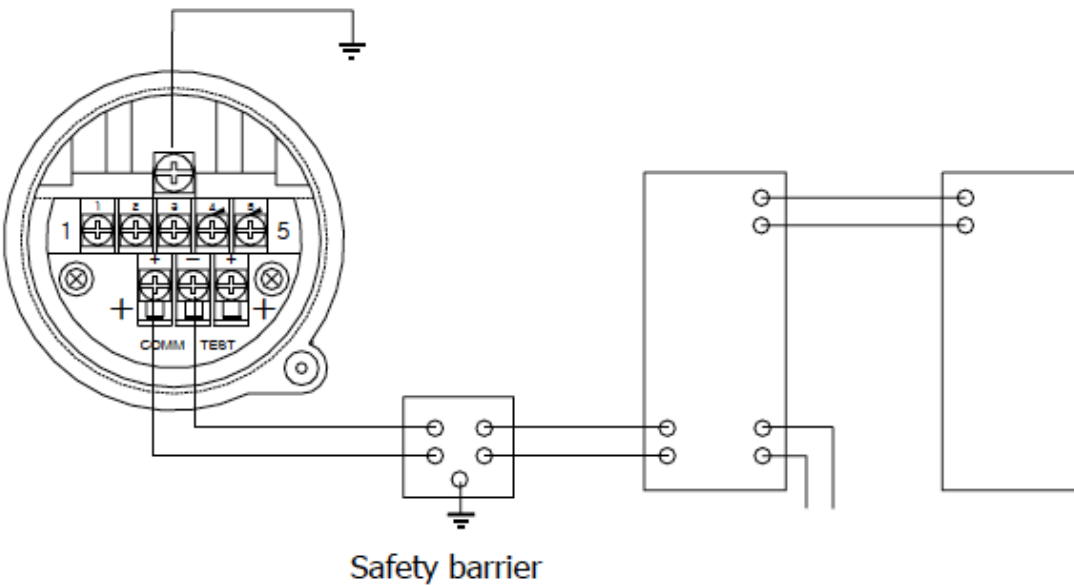

Transmitter Terminal Box

Power Supply Unit

Receiver Instrument

4.6 Wiring Installation

- Use a general-use and intrinsically safe make of cable wiring that uses metallic conduit or waterproof cable glands (safety barrier must be connected to inner loop).

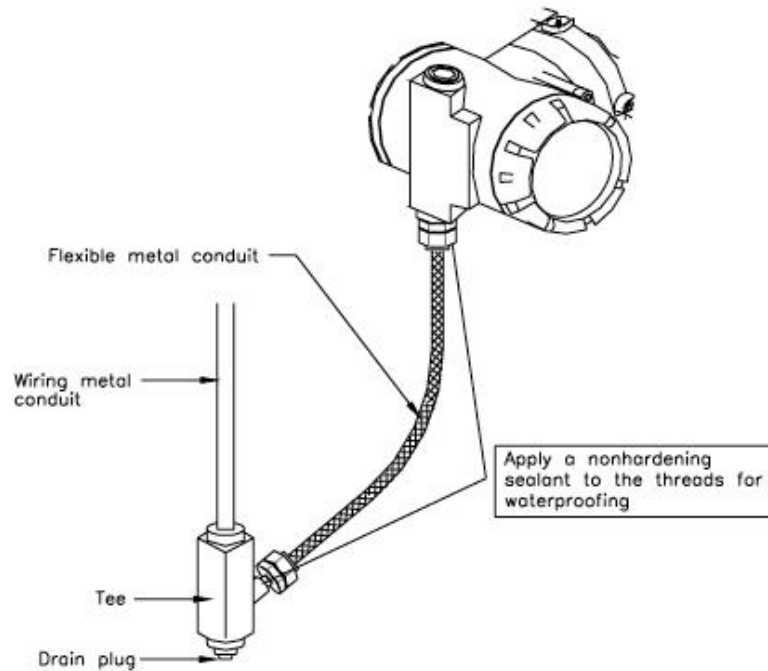

- KOSHA Flameproof type
Use wire cables through a flameproof packing adapter, or using a flameproof metal conduit:
 1. Only use flameproof packing adapter by KOSHA
 2. Apply a non-hardening sealant to the terminal box connection port and to the threads on the flameproof packing adapter for waterproofing
 3. Mount the flameproof packing adapter to the terminal box
 4. Screw the flameproof packing adapter into the terminal box until the O-ring touches the terminal box wiring port (at least 5 full turns), and tighten the lock nut

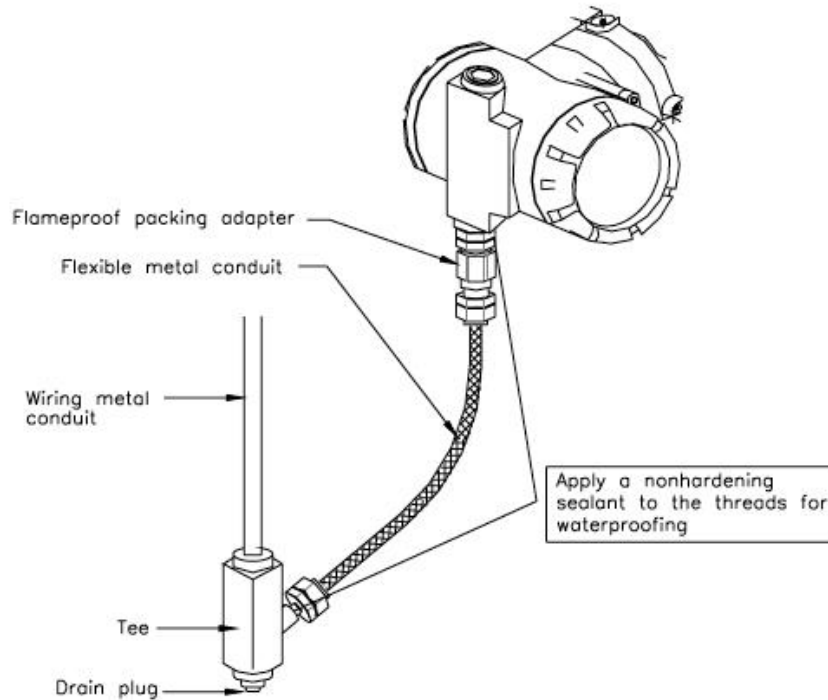

- Flameproof metal conduit wiring:
 1. A seal fitting must be installed near the terminal box connections port for a sealed construction
 2. Apply a non-hardening sealant to the threads of the terminal box connection box, flexible metal conduit and deal fitting for waterproofing

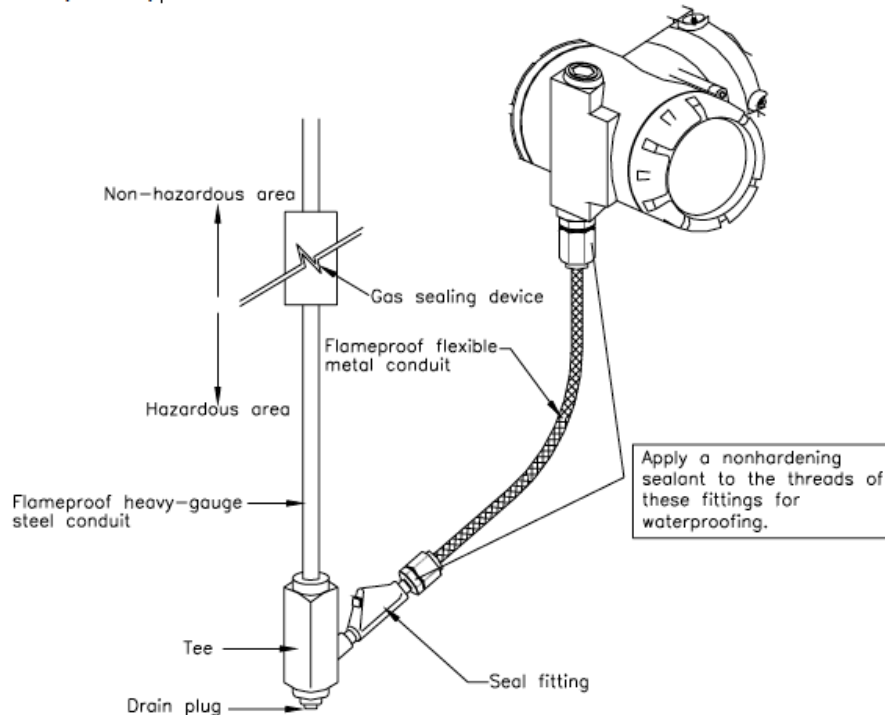

After wiring, impregnate the fitting with a compound to seal tubing.

4.7 Grounding

- Grounding is required below 10 ohm for explosion-proofing and safety
- There is a ground terminal on the inside and outside of the terminal box. Either of these terminals may be used
- Use 600V grade PVC insulated wire for grounding

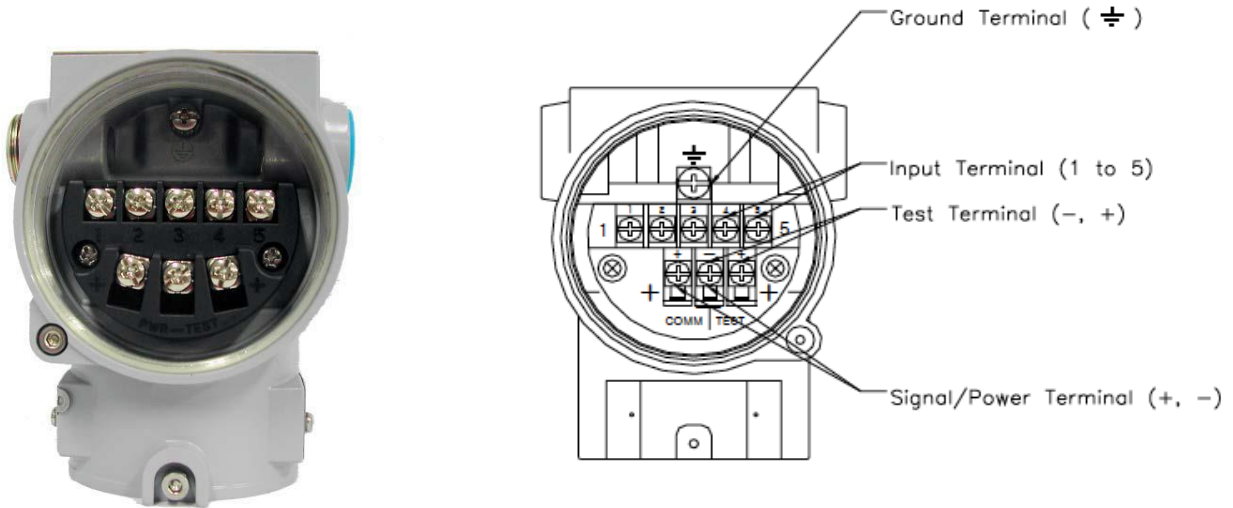

4.8 Power Supply and Load Resistance

When configuring the loop, make sure that the external load resistance is within the range in the figure below. The voltage of transmitter terminal input is same as follows:

Standard Power Supply: 11.9 to 45VDC

And maximum loop current is 24mA, Load Resistance

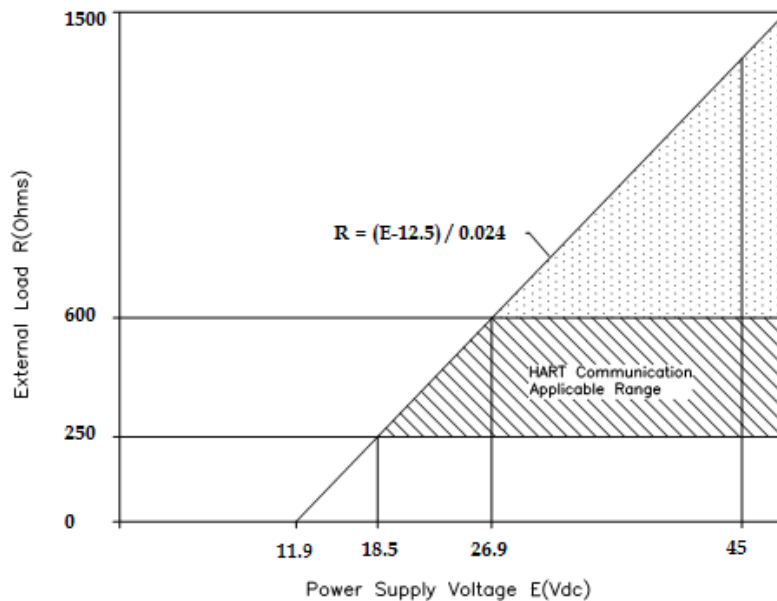

4.9 Environmental Considerations

4.9.1 Effect of Ambient Temperature

You have to install at -40°F to 185°F (-40°C to 85°C), operating ambient temperature range. If predicted heat exceeds or is equivalent to the ambient temperature range limit, consider an additional method to cut-off the process heat.

4.9.2 Environment Having Toxic Material/ Moisture

Housing of the Tek-Temp 2100A can be protected against moisture or toxic material.

The electronic circuit side is separated from terminal side. When the O-ring seal cover is covered, it is safe. However, drips could penetrate the housing of transmitter through the conduit pipeline. Therefore, the transmitter should be set up over the position of conduit pipe to prevent dripping.

4.9.3 Installation in a Dangerous Place

The transmitter is designed with explosion-proof housing. The installation environment of the transmitter must confirm to explosion-proof specifications.

5 Operation

5.1 LCD Display

The Tek-Temp 2100A consists of a 5-digit LCD Display. It shows:

- Error code
- Units (Normal and Engineering)
- Menu and Menu option
- Indication of being in Normal or Engineering mode
- Indication of performing a loop test
- Indication of being in Multi-Drop mode
- 5-digit measured value

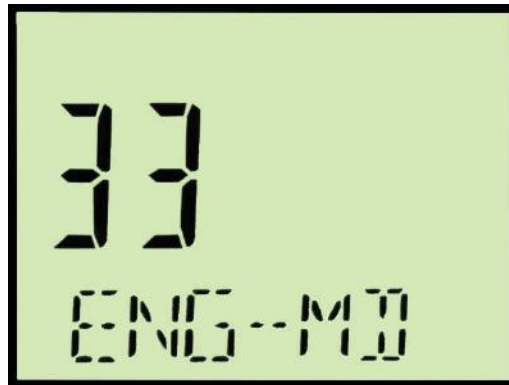

5.2 LCD Screen Rotation

Unscrewing the two screws on either side of the LCD screen allows for the screen to be rotated 90° clock-wise or counter clockwise.



5.3 Fail Mode Alarm

Tek-Temp 2100A Explosion-proof Temperature Transmitter automatically and continuously performs self-diagnostic routines. If the self-diagnostic routines detect a failure, the transmitter drives its output outside of the normal saturation values. The transmitter will drive its output low(down) or high(up) based on the position of the failure mode alarm jumper. The table below shows the output values.

Table: Standard alarm and Saturation value





Level	4 to 20mA Saturation	4 to 20mA Alarm
Low/Down	3.9 mA	≤ 3.8 mA
High/Up	20.5 mA	≥ 21 mA

The Fail Mode Select Jumper switch is in LCD module and main CPU module and Jumper Switch Line is connected circuitally. In the case of no LCD module, we can use CPU module's Fail Mode Select Jumper switch and in the case of LCD module we can use the LCD module's Jumper switch. In this case, the CPU module selected is "Down" side. Not selected and we can select "Down" side.

Table: Fail Mode

Select Fail Mode	Both LCD module and CPU module		Only CPU module
	CPU module	LCD module	
Fail Down	Down	D	D
Fail Up	Down	U	U
	Up	U or D	

Fail Mode and EEPROM-Write Selection Switch on CPU Board

	
EEPROM Writing [Down of Left]	Alarm Down (4mA) [Down of Right]
	
EEPROM Protect [Up of Left]	Alarm Down (20mA) [Up of Right]

Fail Mode and EEPROM-Write Selection Jumper Switch

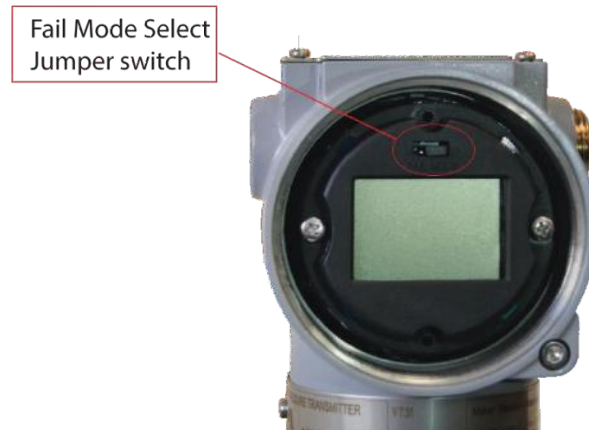

5.4 EEPROM-Write Enable/ Disable Mode Switch

The EEPROM (Electrically Erasable Programmable ROM) restores various configuration variables in the transmitter. To protect against change of the configuration variable data in the software, on the hardware side there is a Write-Protect mode and Jumper switch selected. It is segmented "EEP-Write DIS / EN " in the main CPU module. When you connect the jumper to DIS you can't change the configuration data in EEPROM. When you connect the jumper to EN you can change configuration data in EEPROM. When there is no connected Jumper, it is classified EN. At the factory before shipment, it is configured "EN".

DIP Switch Selection

- Left 1 (WR-EN): EEPROM WRITE En/Disable Setting
- Right 2 (DOWN): Fail Mode ALARM Setting



Jumper Switch



CPU Module Fail Mode, EEPROM-Write Selection Jumper Switch

Below are two security methods in Tek-Temp 2100A:

- CPU Module Jumper Switch
- 1. Fail mode selection
- 2. EEPROM Write Protection

- Security Jumper: protects writing configuration parameters of the transmitter.
- Physically removing Zero and Span Magnetic Buttons from the transmitter: you are not able to regulate Zero and Span in Local.

5.4.1 Security Jumper (EEPROM-Write Protect)

Protects the against a change of Configuration Parameter of the transmitter to Write Protect Jumper.

5.4.2 Zero and Span Magnetic Button

If the magnetic button is moved, you can't configure Zero and Span in Local.

5.5 Configuration of Alarm and Security Jumper Procedures

To change jumper's position, follow the procedure given below:

- If installing the transmitter, cut-off power
- Open the housing front side covers. If there is power supply, don't open the transmitter
- Turn off Jumper, turn on at wanted position
- Close the housing covers. You must fully engage to meet the explosion-proof requirements

5.6 Configuration of Zero and Span Procedures

ZERO and SPAN Buttons are visible when the nameplate of the transmitter is opened.

For the previous version of this transmitter, ZERO, SPAN, ZERO TRIM and ZERO ADJ. functions were supported using ZERO / SPAN buttons; from Version 58, the Units, Range, Damping, LCD decimal set functions are included. The procedure has also changed as below:

However, the ZERO and SPAN set functions are the same as before the revision of Version 58. Using functions which supported by buttons:

- Zero/Span button mounted in the transmitter
- HHT Configurator by HART Communication

Zero/Span configuration process by Zero/Span button of the transmitter:

1. Release both sides bolts of the nameplate in the upper part of the transmitter and push down to the right of the nameplate. This will show the Zero/Span button.

2. Zero Configuration

Set the current process value for Lower Range Value (4 mA).

Put necessary pressure on the Zero button for 10-seconds and push the Zero button for 5-seconds. This will display "Zero" in the LCD window. After checking this message, remove the finger from the button. Press the button for 3 seconds with 1- second intervals. This will display "-ZE-" in the LCD window. When this message is displayed all zero configurations are complete. If the procedure has failed, "SPeR" or "SEtE" will be displayed in the LCD window.

3. Span Configuration

Sets the current process value for Upper Range Value (20 mA).

Put appropriate pressure on Zero for 10 seconds and push the Span button for 5 seconds. This will display as "SPAN" in the LCD window. After checking this message, remove the finger from the button. Press the button for 3 seconds with 1-second intervals. This will display "-SP-" in the LCD window. When this message is displayed, all Zero configurations have completed. If the process has failed, "SPeR" or "SEtE" will be displayed in the LCD window.

- **Error Message**

- a. **"SPeR"**: Setting Value is over Sensor Limit Range or Less Minimum SPAN
- b. **"SEtE"**: Setting Value is not written on memory
- c. **"ZtEr"**: Setting Zero Trim value is 10% over Sensor Max Span
- d. **"bEr1"**: Zero/Span and Zero Trim functions are stopped in the middle of work (button is pressed only one time or pressed continuously. This message is present for Button Error)

5.7 Configuration of Zero Point Adjustment

Zero Point Adjustment means to configure PV value which output after Zero Trim. Zero Point Adjustment is to configure a current PV Value for another value (which is not zero) by configuring the offset value of zero point. This is for configuring a current displayed value for a desired process value without making the process value zero. Especially, in case the of configuring level value, it is very difficult to make Sensor Zero Trim, this adjustment is a very convenient way to configure a current value for a desired value.

There are two ways to achieve Zero Point Adjustment of the Tek-Temp 2100A

- A. Using the Zero/Span button on the transmitter
- B. Using HART communicator, HHT, etc.

The guide below shows a Zero Point Adjustment procedure using Zero/Span button:

- Loosen both bolts of the nameplate on the upside of the transmitter and push the right end of nameplate back a little bit
- Apply necessary pressure and push Zero and Span button simultaneously for 3 seconds. This will display "Z-tr" in LCD window. Continuously push the Zero and Span buttons for 3 seconds again. This will display "Z-AD" in LCD window. After checking this message, it should show that 0.01% diminishes whenever the Zero button is pushed, and 0.01% increases whenever the Span button is pushed. Pushing the button continuously changes the speed to fast or slow. If you push the Zero/Span button for 3 seconds or do not push any button for 30 seconds. "-Zo-" message is displayed in the LCD window. When this message is displayed, all procedures has completed. The range for Zero Point Adjustment is permitted within 100% of Calibrated Span.
- Close the cover of nameplate and lock both bolts.

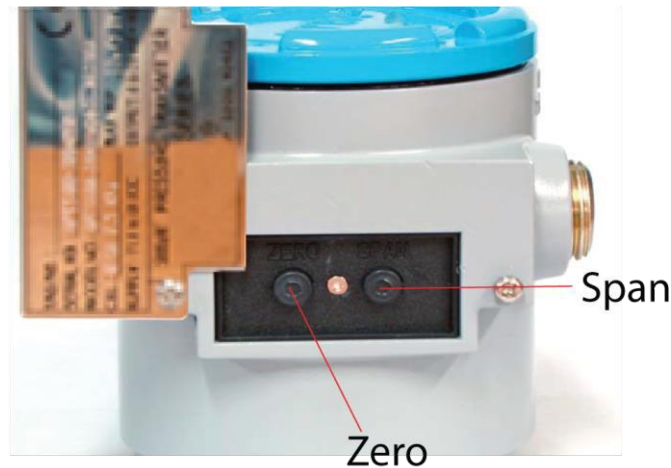

Transmitter's Zero/Span configuration Button

- Refer to Appendix I for Button Error and LCD Display Message

5.8 Shop Commissioning using HHT

Commissioning consists of testing the transmitter, testing the loop, and verifying the transmitter configuration data. The Tek-Temp 2100A Temperature Transmitter may be commissioned using HHT or HART supported either before or after installation.

If you connect a "TEST" pin, it's not communicated. If it doesn't expose electronics circuits after install, you must connect all jumpers to the transmitter in the shop commissioning level. Analog output of the transmitter is 4 - 20 mA, so it requires power supply at 11.9VDC - 45VDC and an Ampere meter for measuring output current. You must connect a 250 - 550ohm resistor in a power loop for HART Communication and HHT or PC Configurator.

POWER / SIGNAL CONNECTIONS

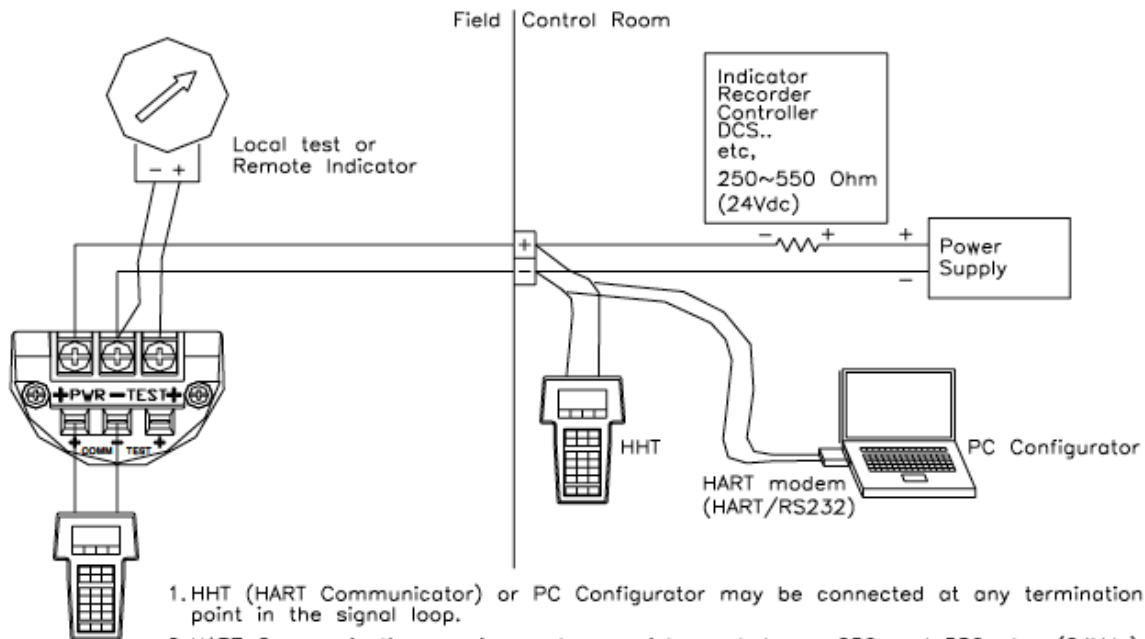

1. HHT (HART Communicator) or PC Configurator may be connected at any termination point in the signal loop.
 2. HART Communication requires a loop resistance between 250 and 550 ohms(24Vdc).
 3. Transmitters operate on 11.9 to 45.0 Vdc transmitter terminal voltage.
- [Applied Power]
- * 11.9 ~ 45.0 Vdc for general operation
 - * 17.4 ~ 45.0 Vdc for HART communication
 - * 17.4 ~ 42.0 Vdc for CSA approval (Power supply must not exceed 42.0 Vdc)

Connecting the Transmitter to HHT

5.9 Commissioning on the Bench with a Hand-Held Terminal

After and before installation, you can handle upon commissioning. However, for correct handling and understanding of the function, before installation you have to handle upon commissioning on the bench with a Hand-Held Terminal.

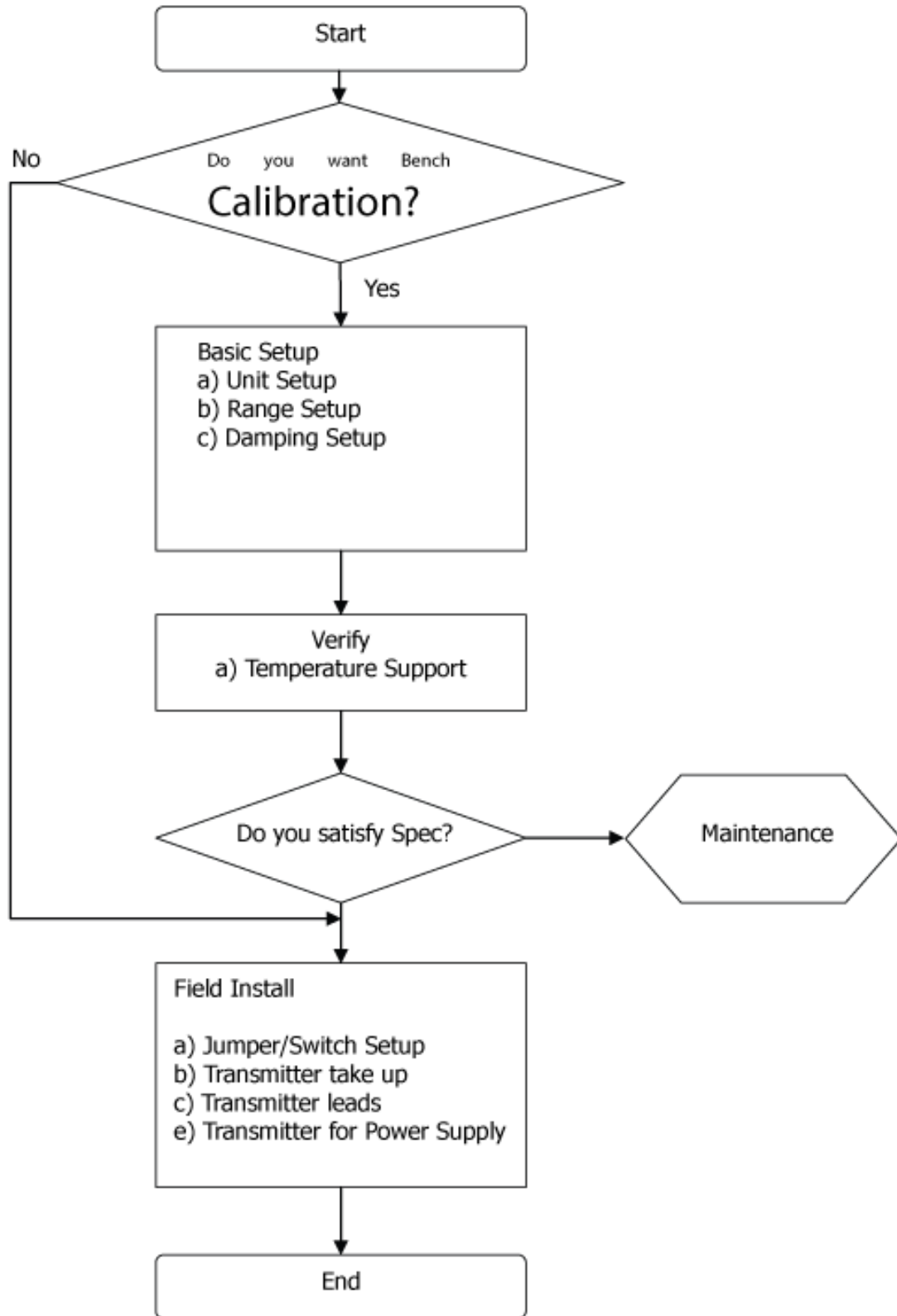

5.10 Description of LCD Messages

The Tek-Temp 2100A Transmitter notifies any cautions and failures to the user through the LCD during operation. Measured Value (Temperature, Resistance, Voltage, etc.) and Unit ($^{\circ}\text{C}$, $^{\circ}\text{F}$, R, T, mV, ohm, etc.) will be shown on the LCD during normal operation.

Generally, the LCD Messages shown below will appear during normal working conditions or the setting's inner memory.

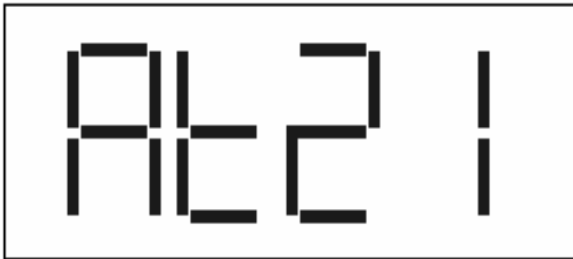

This message will be shown at the initial time that power is supplied



This message will be shown when resetting CPU inner EEPROM Data, and transmitter will be reset when the resetting procedure is done.



Shown when above EEPROM resetting or transmitter reoperation according to reoperation message.

The figures below show the different self-diagnostic functions or failures during operation, and reverts back to normal condition when the failures are removed.



This message present for failures of the sensors such as short circuit, break-down of wire, abnormal wiring, and reverts back to normal condition when the failures are removed.

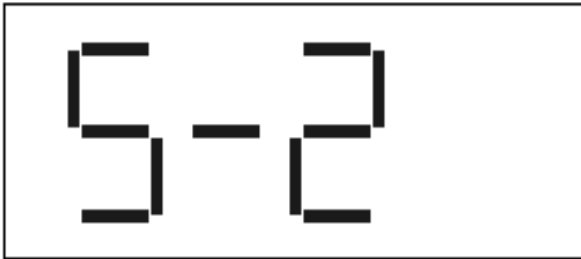

Shown when occur inner failure of transmitter operation occurs, and reverts back to normal condition when the failures are removed.

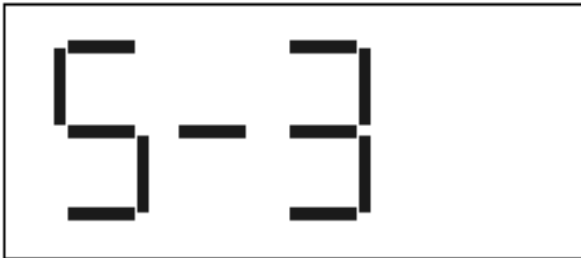

Shown when there is an inner parameter's data error, reverts back to normal condition when the failures are removed.



Shown with abnormal sensor type, and reverts back to normal condition when the failures are removed.



Shows the polling address when in multi-mode

The figures below show the different messages when setting Zero / Span using the buttons on the top of the transmitter. The first two messages are normal setting conditions and following two messages are abnormal setting conditions.

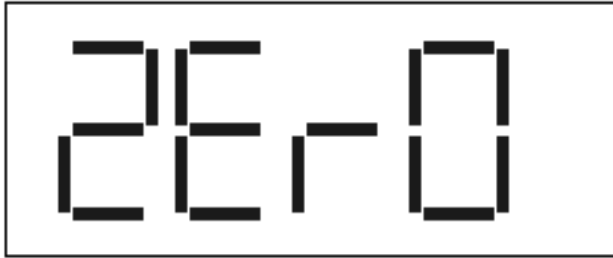

Shown when normally set Zero the current value



Shown when normally set Span the current value

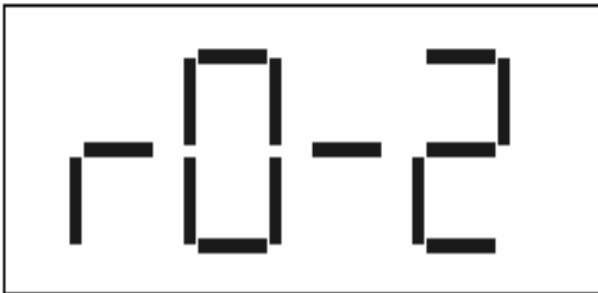

Shown when the target Zero input value is over sensor limit (Minimum Span) in case Span is +, and the input value must be less than sensor limit (Minimum Span)



Shown when prohibited writing on EEPROM of inner CPU. In this case, Zero and Span setting is impossible (Permit after EEPROM Writing enable setting)

5.11 On-line Operations

This chapter describes the configure function of the Tek-Temp 2100A Explosion-proof Temperature Transmitter. This transmitter can be configured to On-Line or Off-Line mode. In On-Line Configuration Mode, you must connect a configuration such as HHT (Hand Held Terminal), etc. Configuration data inputs into the working register of HHT and this data is sent to the corresponding transmitter.



WARNING

Explosion can result in death or serious injury.

- Do not remove the transmitter covers in explosive environments when the circuit is alive
 - In explosive environments, check the transmitter is installed according to safety regulations, before the HHT is connected to the transmitter
 - Transmitter covers must be fully engaged to meet explosion-proof requirements
 - Only a suitably trained and qualified person must establish the transmitter
 - Avoid contact with the leads and terminals. High voltage that may be present on leads and can cause electric shock
-

5.11.1 Configuration of Current to Passive Mode

In the case of a short current loop, you must configure the current loop to passive mode to send or request data to change the transmitter. Don't believe the message indicating HHT; you must configure the Current Loop to passive mode with another operation.

5.11.2 Configuring Data Review

In cases of installing the transmitter in a factory site, before operating the transmitter re-examine and certify whether the configuration data corresponds with the factory application environment.

5.11.3 Check Output

Before others handle the transmitter, you must examine and confirm whether the transmitter operates properly and can suitably configure process variables.

- **Process Variable**

We use two process variables in Tek-Temp 2100A Explosion-proof Temperature Transmitter. The pressure value is the Primary Variable and temperature value of pressure value configure SV (Secondary Variable) with fixed value.

Moreover, this PV value outputs with 4 to 20mA analog value.

5.11.4 Basic Setup

You must configure the correlation variable for operating the current transmitter.

- **Select Sensor Range**

The temperature range to measure is dependent on the range code of the sensor. This value is automatically classified from the Temperature sensor module.

- **Set Output Units**

Select from the following engineering units:

Unit: °C, °F, °R, °K, etc.

- **Re-range**
Set the Zero and Span of 4 - 20mA analog output.

5.11.5 Detailed Setup

- **Set Fail Mode**
When the sensor is wrong or the microprocessor of the transmitter doesn't operate normally in order to output the current value of High or Low.
- **Set Damping Time**
The sensor input value changes the response time of the transmitter into smooth variations of output readings caused by rapid changes in input. Determine the appropriate damping setting based on the necessary response time, signal stability, and other requirements of the loop dynamics of your system. The default damping value is 1.0 seconds, and can be reset to damping values between 0 - 60 seconds.

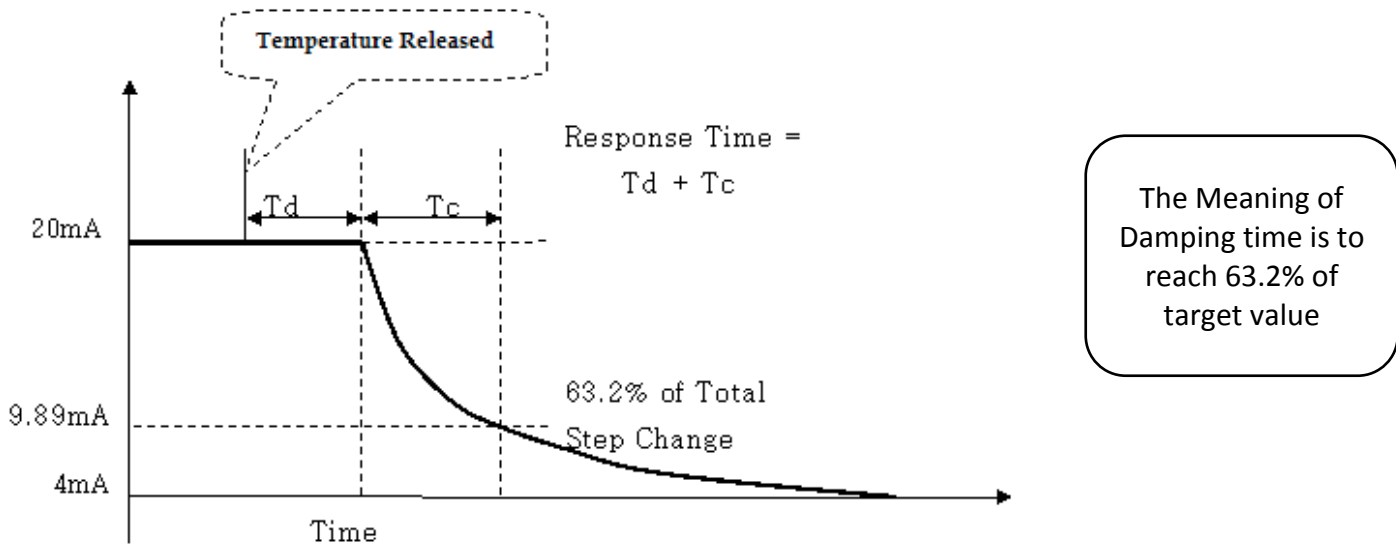

5.11.6 Configuration of Information Variable

- **Set Tag**
Tag Variable is an easy method to classify the transmitter in a multi-transmitter installation environment. Tag Character can be used; up to 8 words/numbers in of English.
- **Set Messages**
When use several transmitters, user can define for classification each transmitter and use 32 words of English/number. This message is saved in EEPROM of transmitter.

5.11.7 Configuration of Breakdown Diagnostic Function

- **Loop Test**

The Loop Test verifies the output of the transmitter, the integrity of the loop, and the operations of any recorders or similar devices installed loop. Perform the following procedure for a loop test.

- a. Connect a reference meter to the transmitter.
- b. Select the Loop Test of HHT and operate the Loop Test.
- c. Select output current (4mA/20mA/etc.)
- d. If the readings match, then the transmitter and the loop are configured and functioning properly.

If the readings do not match, then you may have the current meter attached to the wrong loop, there may be a fault in the wiring, the transmitter may require an output trim, or the electrical current meter may be malfunctioning.

5.11.8 Calibration

A scaled system is implemented by calibrating the transmitter. Trim functions have several functions for the calibration. Explosion-proof Transmitters operate differently than analog transmitters. A Smart Transmitter uses a microprocessor that contains information about the sensor's specific characteristics in response to pressure and temperature inputs for calculating the Process Variable. The trim and re-range functions also differ. Re-ranging sets the transmitter analog output to the selected upper and lower range points and can be done with or without applied pressure. Reranging does not change the factory characterization curve stored in the microprocessor. Sensor trimming requires an accurate pressure input and adds additional compensation; this adjusts the position of the factory characterization curve to optimize transmitter performance over a specific pressure range. Re-range functions provide the ability to re-adjust the 4 to 20mA points sensor inputs.

5.12 Menu Tree

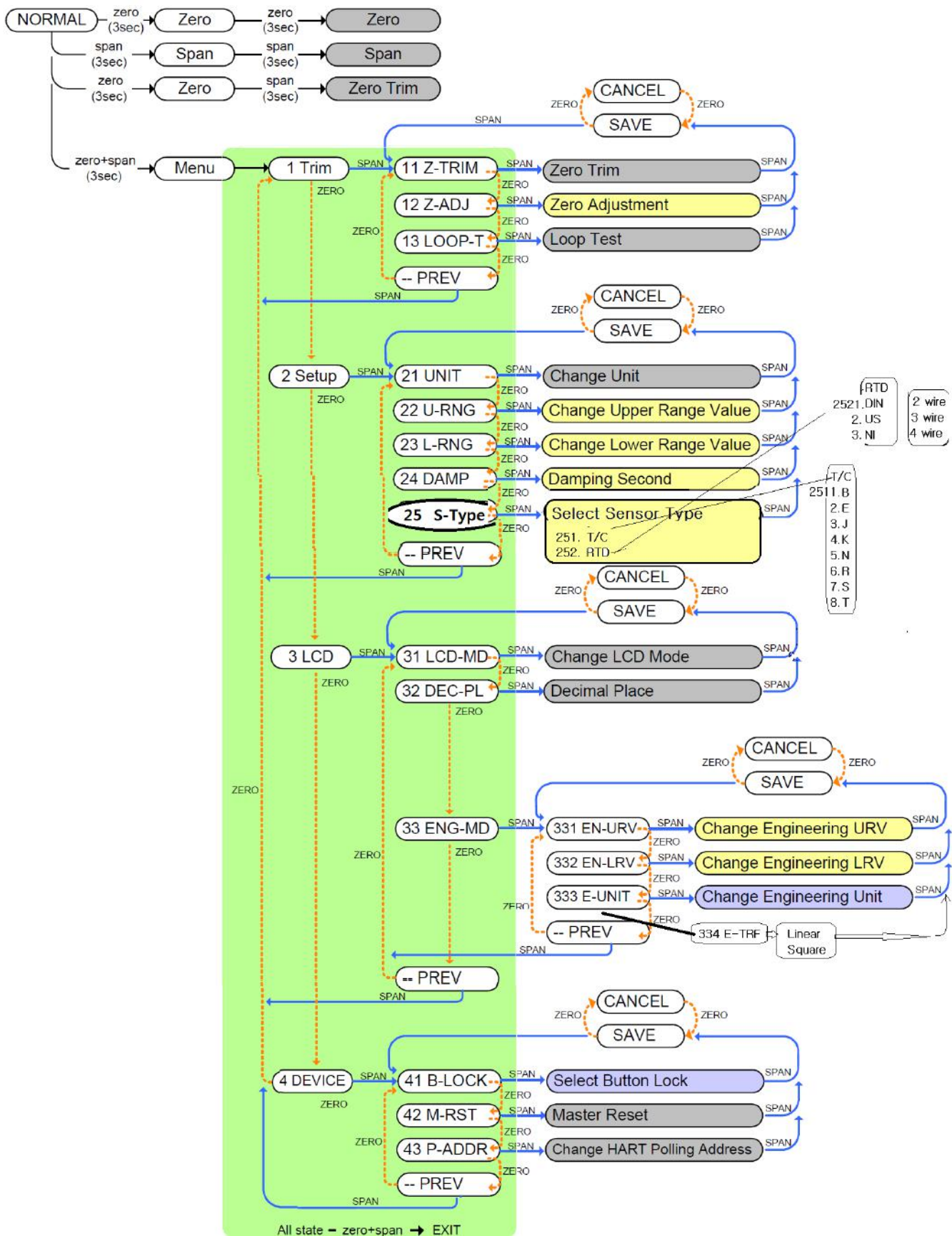

6 Maintenance



WARNING

Explosion can result in death or serious injury.

- Do not remove the transmitter covers in explosive environments when the circuit is alive
- In explosive environments, check the transmitter is installed according to safety regulations, before the HHT is connected to the transmitter
- Transmitter covers must be fully engaged to meet explosion-proof requirements
- Only a suitably trained and qualified person must establish the transmitter
- Avoid contact with the leads and terminals. High voltage that may be present on leads and can cause electric shock

6.1 Hardware Diagnostics

If you suspect a malfunction despite the absence of any diagnostic messages on the HHT, follow the table below to verify that the transmitter hardware and process connections are in good working order:

Symptom	Potential Source	Corrective Action
Transmitter does not Communicate with HART Communicator	Loop Wiring	<ul style="list-style-type: none"> • Check for a minimum of 250 ohms resistance between the power supply and HHT • Check for adequate voltage to the transmitter. The transmitter always requires 11.9 to 45 VDC • Check for intermittent shorts, open circuits, and multiple grounds
High Output	Sensor Input Failure	Connect HHT and enter the transmitter test mode to isolate a sensor failure
	Loop Wiring	Check for dirty or defective terminals, interconnecting pins, or

		receptacles
	Power Supply	Check the output voltage of the power supply at the transmitter terminals. It should be 11.9 to 45 VDC in spite of loop scale
	Electronics Module	Connect HHT and enter the transmitter test mode to isolate module failure. Check the sensor limits to ensure calibration adjustments are within the sensor range
Erratic Output	Loop Wiring	<ul style="list-style-type: none"> • Check the output voltage of the power supply at the transmitter terminals. It should be 11.9 to 45 VDC • Check for intermittent shorts, open circuits, and multiple grounds • Check for proper polarity at the signal terminals • In case OF measuring electric current while digital communication, output appear around $\pm 0.013\text{mA}$
	Electronics Module	Connect HHT and enter the transmitter test mode to isolate an electronics mode failure
	Loop Wiring	<ul style="list-style-type: none"> • Check for adequate voltage to the transmitter. The transmitter always requires 11.9 to 45 VDC

		<ul style="list-style-type: none"> • Check for intermittent shorts, open circuits, and multiple grounds • Check polarity of the signal terminal • Check the loop impedance
	<p>Electronics Module</p>	<p>Connect the HHT and check the sensor limits to ensure calibration adjustments are within the sensor range.</p>

6.2 Hardware Maintenance

Tek-Temp 2100A Explosion-proof Transmitters have no moving parts and require a minimum of scheduled maintenance. Both transmitters feature modular design for easy maintenance. If you suspect a malfunction, check for an external cause before performing the diagnostics as discussed later in this section.

6.2.1 Test Terminals

The test terminal is marked as TEST on the terminal block. The test and negative terminals are connected to the test terminals; so long as the voltage across the receptacles is kept below the diode threshold voltage, no current passes through the diode. To ensure that there is no leakage current through the diode while making a test reading, or while an indicating meter is connected, the resistance of the test connection or meter should not exceed 10 ohms. A resistance value of 30 ohms will cause an error of approximately 10 % of reading.

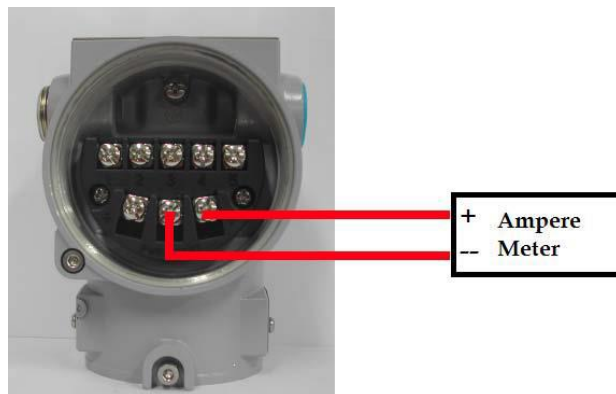

Loop Test Terminal

6.2.2 Disassembling of Electronics Housing

The transmitter is designed with dual-compartment housing; one contains the electronics module, and the other contains all wiring terminals and the communication receptacles.

Structure of Housing



- **Disassembling Electronics Structure Module**
Use the following procedure to remove the electronics module:

i NOTE

The electronics are sealed in a moisture-proof plastic enclosure referred to as the electronics module. The module is a non-repairable unit; if a malfunction occurs the entire unit must be replaced

1. Disconnect the power to the transmitter.
2. Remove the cover from the electronics side of the transmitter housing. Do not remove the instrument cover in explosive atmospheres when the circuit is alive. Remove the LCD meter, if applicable.
3. Remove the two screws that anchor the electronics module to the transmitter housing.
4. Firmly grasp the electronics module and pull it straight out of the housing, taking care not to damage the interconnecting pins.

i NOTE

The transmitter EEP-Write jumpers and fail-mode are located on the front of the electronics module. When it is replaced with a new one, use the same jumper location



Structure of Electronics Module Inner Transmitter

- **Fail Mode and Jumper Switch of EEPROM-Write**
Fail-mode and jumper switch of the EEPROM-write is located at the front of electronics module.

6.2.3 Assembling the Electronics Structure

The re-assembling procedure is same as follows:

- Make sure that fail-mode and jumper switch are set exactly
- Insert the electronics module into the housing
- Connect the connector of sensor board with power connector
 - a. Misconnection of the two connectors can cause wrong output(4 to 20mA) and effect the power of transmitter
 - b. In case of the power connector being sandwiched between board and housing, it may cause the wrong output signal and effect the power of transmitter
- Fix the electronics module with 3 screws
- Close the cover of the housing

Connection of sensors.

Connections with Sensors (Thermocouple, RTD) are as follows:

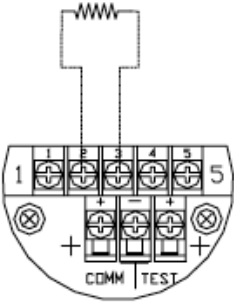
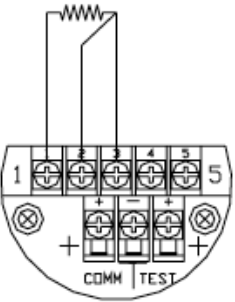
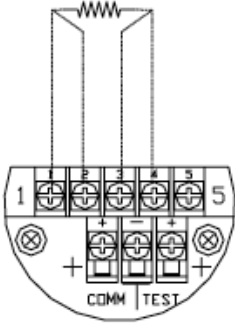
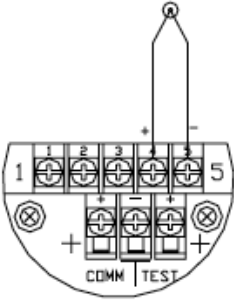
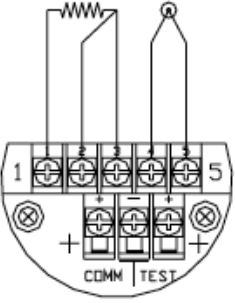
		
<p>2-Wire RTD and Ohms</p>	<p>3-Wire RTD and Ohms</p>	<p>4-Wire RTD and Ohms</p>
		
<p>Thermocouples and millivolts</p>	<p>diff.T/dual Sensor with RTD/Thermocouple</p>	

7 Appendix

Tek-Temp 2100A Explosion-proof Temperature Transmitter LCD Display error codes.

Message	Description
ADRE	ADC Initial Error
2-tr	Zero Trim button pressed
2ero	Zero button pressed
Span	Span button pressed
Ber1	Button Input Sequence Error
2ter	Zero Offset Value over
-tr-	Trim Done
Sper	Setting Limit Error when button input
-2e-	Zero function complete
-sp-	Span function complete
-20-	Zero Trim or Zero Adjustment complete
F-RS	Flash Configuration Data Reset
F-FL	Flash Reset failure
-FR-	Flash Reset complete
A-RS	Analog EEPROM Initializing Start
A-CP	Analog EEPROM Copy
A-FL	Analog EEPROM Copy Failure
-AC-	Analog EEPROM Copy complete
s-fl	Sensor Fail
Anbf	Analog EEPROM fail or Temperature Sensor fail
EOSC	Oscillator Fault
FAVE	Flash Access Violation
NMIE	NMI Interrupt



TEKMATION LLC reserves the right to change the designs and/or materials of its products without notice. The contents of this publication are the property of TEKMATON and cannot be reproduced by any other party without written permission. All rights reserved. Copyright © 2016 TEKMATON LLC
DOC:TEK/AV/WNL/IM-2100A/0218/8
TEKMATION LLC



www.tek-trol.com

Tek-Trol is a fully owned subsidiary of TEKMATON LLC. We offer our customers a comprehensive range of products and solutions for process, power and oil & gas industries. Tek-Trol provides process measurement and control products for Flow, Level, Temperature & Pressure Measurement, Control Valves & Analyzer systems. We are present in 15 locations globally and are known for our knowledge, innovative solutions, reliable products and global presence.

Tek-Trol LLC

796 Tek Drive Crystal Lake, IL 60014 USA

Tel.: +1 847 857 6076 , +1 847 655 7428 Fax: +1 847 655 6147

Email: tektrol@tek-trol.com

www.tek-trol.com