



TEK-BAR 3120A

Explosion-Proof Gauge Pressure Transmitter

Instruction Manual

Document Number: IM-3120A



www.tek-trol.com

NOTICE

Read this manual before working with the product. For personal and system safety, and for optimum product performance, make sure you thoroughly understand the contents before installing, using, or maintaining this product.

For technical assistance, contact

Customer Support

796 Tek-Drive

Crystal Lake, IL 60014

USA

Tel: +1 847 857 6076, +1 847 655 7428

© COPYRIGHT Tek-Trol LLC 2019

No part of this publication may be copied or distributed, transmitted, transcribed, stored in a retrieval system, or translated into any human or computer language, in any form or by any means, electronic, mechanical, manual, or otherwise, or disclosed to third parties without the express written permission. The information contained in this manual is subject to change without notice.

Table of Contents

1	Safety Instructions	3
1.1	Intended Use	3
1.2	Certification	3
1.3	Safety Instructions from the Manufacturer	3
1.3.1	Disclaimer	3
1.3.2	Product Liability and Warranty	3
1.3.3	Information Concerning the Documentation	3
1.4	Safety Precautions	4
1.5	Packaging, Transportation, and Storage	5
1.5.1	Packaging	5
1.5.2	Transportation	5
1.5.3	Storage	5
1.6	Nameplate	6
2	Product Description	7
2.1	Introduction	7
2.2	Measuring Principle	7
2.3	Specifications	8
2.3.1	General Specifications	8
2.3.2	Electrical Specifications	8
2.3.3	Physical Specifications	9
2.3.4	Measuring Range Limit for Tek-Bar 3120A	9
2.4	Exploded View of Transmitter	10
2.5	Dimensional Drawings	10
2.6	Model Chart	11
3	Installation	12
3.1	Selecting the Installation Location	12
3.2	Installation Procedure	13
3.2.1	Mount the Transmitter Using Mounting Brackets	13
3.2.2	Housing Rotation	14
3.2.3	Terminal Side of Transmitter	14
3.2.4	LCD Display Rotation	14
3.2.5	Conduit Installation	15
3.2.6	Mounting Requirements	15
3.2.7	Liquid Flow Measurement	15
3.2.8	Gas Flow Measurement	16
3.2.9	Steam Flow Measurement	16
3.2.10	Zero Trim after Installation	17
4	Electrical Connection	18
4.1	Grounding of Measuring Device	18
4.2	Power Supply Connection	19
4.3	Connection to the HART Handheld Communicator	19

5	Operation	21
5.1	Local Operation and Display	21
5.1.1	Operation Without Display	21
5.1.2	Operation With LCD Display	21
5.2	Basic Setup	22
5.2.1	Failure Mode Alarm.....	22
5.2.2	Damping Time	23
5.2.3	Security Jumper (EEPROM-Write Protect)	23
5.2.4	Loop Test.....	23
5.3	Configuration.....	24
5.3.1	Zero and Span Magnetic Buttons.....	24
5.3.2	Advance Configuration Via Push Button.....	25
5.3.3	Steps to Input Numeric Data Value.....	26
5.3.4	Push Button Sequence for Each Programming Sub-Menu	28
5.3.4.1	Zero Trim (Sub Menu 11)	28
5.3.4.2	Zero Adjustment (Sub-Menu 12).....	28
5.3.4.3	Change Units (Sub-Menu 21) – Example Set Units to “psig”	29
5.3.4.4	Change URL/ Upper Range Value (Sub-Menu 22)	29
5.3.4.5	Change LRL/ Lower Range Value (Sub-Menu 23)	30
5.3.4.6	Changes Damping Value (Sub-Menu 24).....	31
5.3.4.7	Change LCD Mode (Cyclic or Fixed Display) (Menu 31).....	31
5.3.4.8	Change LCD Resolution (Sub-Menu 32)	32
5.4	Menu Tree	33
5.5	Handheld Communicator	35
6	Troubleshooting.....	36
6.1	Hardware Diagnostics	36
6.2	Error Codes.....	38

1 Safety Instructions

1.1 Intended Use

Tek-bar 3120A is a Pressure Transmitter used for measuring gauge and absolute pressure.

The manufacturer is not liable for damage caused by improper or non-designated use.

1.2 Certification

Tek-Bar 3120A has FM approval (Class I Div. I)

1.3 Safety Instructions from the Manufacturer

1.3.1 Disclaimer

The manufacturer will not be held accountable for any damage that happens by using its product, including, but not limited to direct, indirect, or incidental and consequential damages.

Any product purchased from the manufacturer is warranted in accordance with the relevant product documentation and our Terms and Conditions of Sale.

The manufacturer has the right to modify the content of this document, including the disclaimer, at any time for any reason without prior notice, and will not be answerable in any way for the possible consequence of such changes.

1.3.2 Product Liability and Warranty

The operator shall bear authority for the suitability of the device for the specific application. The manufacturer accepts no liability for the consequences of misuse by the operator. Wrong installation or operation of the devices (systems) will cause the warranty to be void. The respective Terms and Conditions of Sale, which forms the basis for the sales contract shall also apply.

1.3.3 Information Concerning the Documentation

To prevent any injury to the operator and damage to the device it is essential to read the information in this document and read the applicable national standard, and safety instruction. These operating instructions contain all the information that is required in various stages, like product identification, incoming acceptance and storage, to mounting, connection, operation and commissioning through to troubleshooting, maintenance and disposal.

1.4 Safety Precautions

You must read these instructions carefully prior to installing and commissioning the device. These instructions are an important part of the product and must be kept for future reference. Only by observing these instructions, optimum protection of both personnel and the environment, as well as safe and fault-free operation of the device can be ensured.

For additional information that are not discussed in this manual, contact the manufacturer

Warnings and Symbols Used

The following safety symbol marks are used in this operation manual and on the instrument.



WARNING

Indicates a potentially hazardous situation which, if not avoided, could result in death or serious injury



CAUTION

Indicates a potentially hazardous situation which, if not avoided, may result in minor or moderate injury. It may also be used to alert against unsafe practices.



NOTE

Indicates that operating the hardware or software in this manner may damage it or lead to system failure.

1.5 Packaging, Transportation, and Storage

This section contains information regarding packaging, transportation, and storage.

1.5.1 Packaging

The original package consists of

1. Tek-Bar 3120A Explosion-Proof Gauge Pressure Transmitter
2. Accessories (optional)
3. Documentation



i NOTE

Unpack and check the contents for damages or signs of rough handling. Report damage to the manufacturer immediately. Check the contents against the packing list provided.

1.5.2 Transportation

- Avoid impact shocks to the device and prevent it from getting wet during transportation.
- Verify local safety regulations, directives, and company procedures with respect to hoisting, rigging, and transportation of heavy equipment.
- Transport the product to the installation site using the original manufacturer's packing whenever possible.

1.5.3 Storage

If this product is to be stored for a long period of time before installation, take the following precautions:

- Store your product in the manufacturer’s original packing used for shipping.
- Storage location should conform to the following requirements:
 - Free from rain and water
 - Free from vibration and impact shock
 - At room temperature with minimal temperature and humidity variation
- Before storing a used flowmeter remove any fluid from the flowmeter line completely. Properties of the instrument can change when stored outdoors.

1.6 Nameplate

The nameplate lists the order number and other important information, such as design details and technical data.



NOTE

Check the device nameplate to ensure that the device is delivered according to your order. Check for the correct supply voltage printed on the nameplate.

TAG NO. :	_____		
SERIAL NO. :	_____		
MODEL NO.:	_____		
CAL.:	_____	MAX W.P. :	_____
SUPPLY:	_____	OUTPUT:	_____
	EXPLOSION-PROOF GAUGE PRESSURE TRANSMITTER		
Tek-Bar 3100 SERIES			
Crystal lake, IL60014, USA			

2 Product Description

This section covers the reference and specification data, as well as ordering information.

2.1 Introduction

The Tek-Bar 3120A Explosion-Proof Gauge Pressure Transmitters have excellent stability, high accuracy, and include features that facilitate easy installation, start up, and minimum maintenance thereby lowering process downtime and overall cost of ownership in the long run. These transmitters are equipped with an automatic temperature compensation function integrated into its advanced signal processing circuitry to ensure high reliability and performance corresponding to change of ambient temperature.

2.2 Measuring Principle

The Tek-Bar 3120A uses piezo-electric pressure transducer. It consists of quartz crystal, which is made from silicon and oxygen arranged in crystalline structure (SiO_2). That crystal is inserted between a solid base and the pressure sensing diaphragm. If pressure is applied, the same force will fall on the pressure sensing diaphragm that pressure to stretch or bend the crystal and an electric potential is generated. The voltage produced will be proportional to the magnitude of the applied pressure.

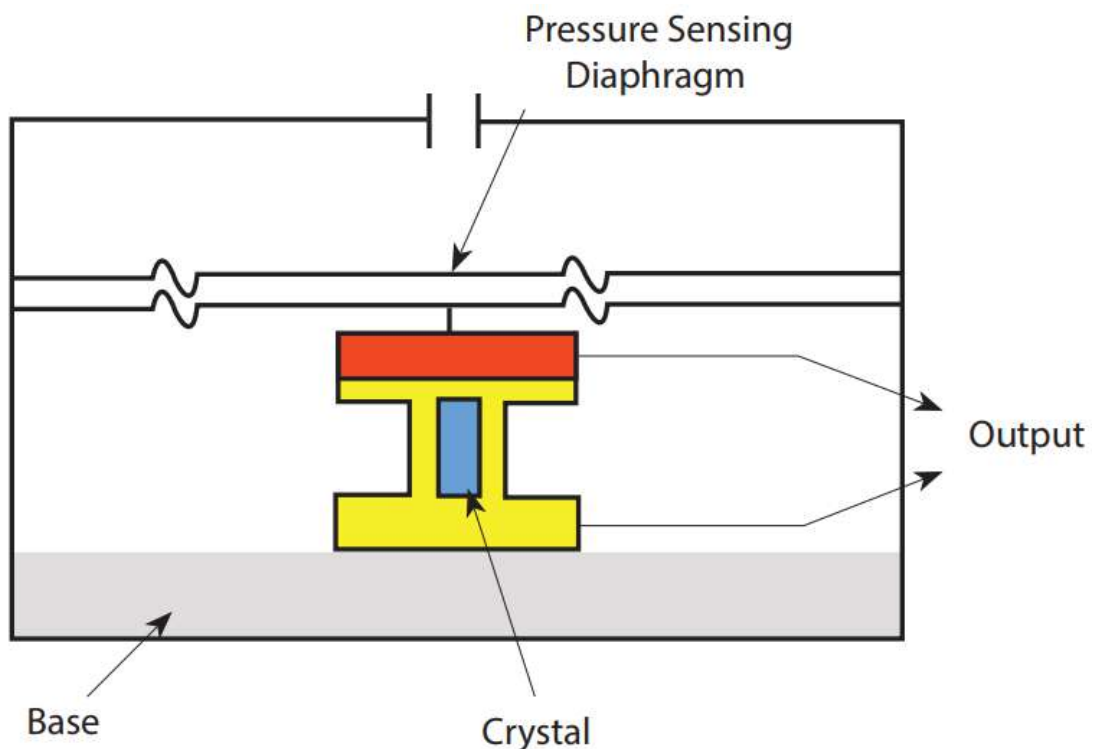

2.3 Specifications

2.3.1 General Specifications

Parameter	Description
Accuracy	± 0.075% of Span
Turndown	100:1
Stability	±0.125% URL for 36 Months
Process Temperature Limits	-40°F to 248°F (-40°C to 120°F)
Ambient Temperature Effect	± [0.019%URL+0.125% Span] / 82.4°F
Ambient Temperature	-40°F to 185°F (-40°C to 85°C)
Humidity Limits	5% to 100% RH
Damping Time	0.25 to 60sec
Power Supply Effects	±0.005% of Span per Volt
Mounting Position Effects	Zero Shift up to 350Pa No Span Effect
Display(optional)	5 Digit LCD Display
Failure Mode	Fail High: Current ≥ 21.1 mA
	Fail Low: Current ≤ 3.78 mA

2.3.2 Electrical Specifications

Parameter	Description
Power Supply	12 to 45 VDC
HART Loop Resistance	250 to 550 ohms
Output Signal	4 mA to 20 mA with HART®
Isolation	500 Vrms (707 VDC)

2.3.3 Physical Specifications

Parameter	Description
Isolating Diaphragm	316L SST
Drain & Vent Valve	316 SST
Flange & Adapter	316 SST
O-ring	Viton, PTFE
Fill Fluid	Silicone Oil or Inert Fill
Paint	Epoxy-Polyester or Polyuret
Mounting Bracket	304 SST with U-bolt (304SST) for 2-inch Pipe
Nameplate	304 SST
Electronic Housing	Aluminum (option:316L SST)
Bolts & Bolting Flange	304 SST
Process Connection Size	¼" NPT Female
Electrical Connections	½" NPT Female
Weight (excluding option items)	8.59lb (Standard) 11.79lb (SST Housing)
2" Pipe Stanchion Type bracket	Angle or Flat type
Housing Class	Waterproof (IP67), 4X
Approvals	FM (class I, Div. I)

2.3.4 Measuring Range Limit for Tek-Bar 3120A

Range Code	Range		Calibrated Span (Min. to Max.)	
	kPa	psig	kPa	psig
3	-100 to 150	-14.5 to 21	1.5 to 150	0.22 to 21
4	-100 to 1,500	-14.5 to 217	15 to 1,500	2 to 217
5	0 to 5,000	0 to 725	50 to 5,000	7.25 to 725
6	0 to 25,000	0 to 3600	250 to 25,000	36 to 3600
7	0 to 60,000	0 to 8500	600 to 60,000	87 to 8700

2.4 Exploded View of Transmitter

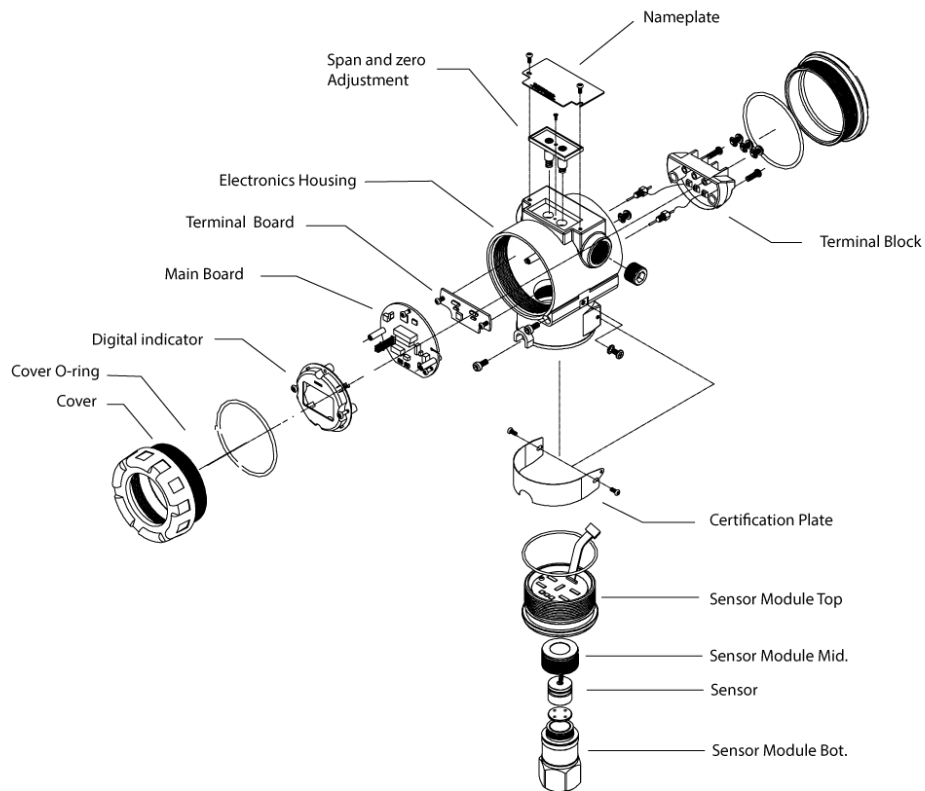

2.5 Dimensional Drawings

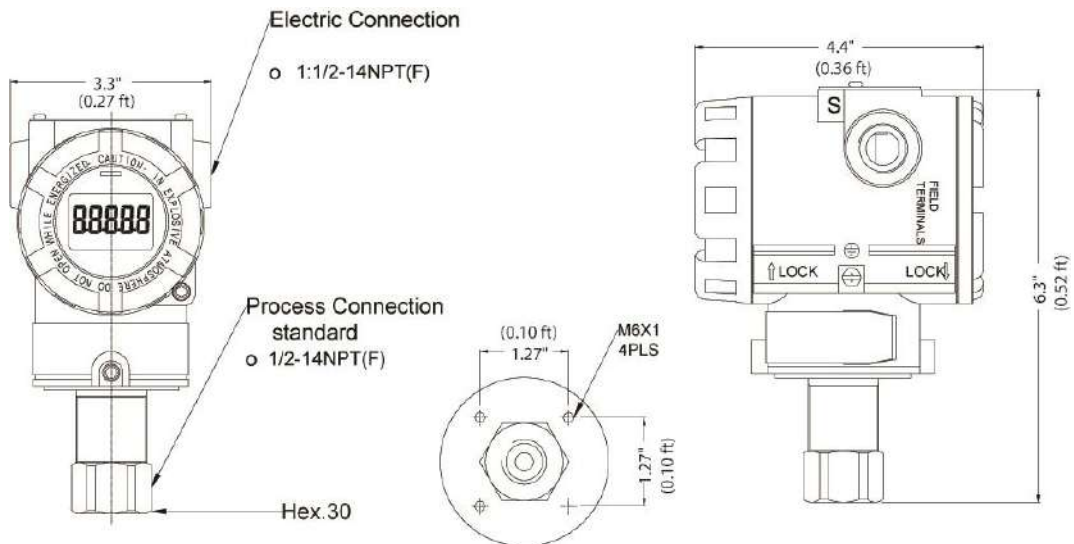

2.6 Model Chart

Example	Tek-Bar 3120A-G	G	3	FM	1	1	LCD	Tek-Bar 3120A-G-3-FM-1-1-LCD
Series	Tek-Bar 3120A-G							Explosion-Proof Gauge Pressure Transmitter
Sensor Type		G A						Gauge Pressure Absolute Pressure
Size			3 4 5 6 7					-14.5-21 psig (factory set 0 to 21 psig) -14.5-217 psig (factory set 0 to 217 psig) 0-725 psig 0-3600 psig 0-8500 psig
Approval Rating				FM				FM Approval (Class I Div I)
Process Connection					1 X			½" NPT Female Diaphragm Seal
Electrical Connection						1		½" NPT Female
Options							LCD MFI SSH CC FC BA BF TAG LP LV	5 Digit LCD Multi Funtional Indicator (With advanced local UI/UX) 316 Stainless Steel Housing Custom calibration with 5 point Calibration Certificate Factory Configuration, No Certificate (Need customer range) Stainless Steel Bracket (Angle type) with SST Bolts Stainless Steel Bracket (Flat type) with SST Bolts Custom etching of the name plate (Must specify on P.O.) Lighting Protection 2 VDC, Low Volt, 4-wire, 1-5 VDC Output, No HART (Must include MFI option)

3 Installation

This section covers instructions on installation and commissioning. Installation of the device must be carried out by trained, qualified specialists authorized to perform such works.



CAUTION

- When removing the instrument from hazardous processes, avoid direct contact with the fluid and the meter
 - All installation must comply with local installation requirements and local electrical code
-

3.1 Selecting the Installation Location

The transmitter is designed to withstand the severe environmental conditions. However, to ensure stable and accurate operation for the years, observe the following precautions when selecting an installation location.

- **Ambient Temperature**
Avoid locations subject to wide temperature variations or a significant temperature gradient. If the location is exposed to radiant heat from plant equipment's, provide adequate thermal insulation and/or ventilation.
- **Ambient Atmosphere**
Avoid installing the transmitter in a corrosive atmosphere. If the transmitter must be installed in a corrosive atmosphere, there must be adequate ventilation as well as measures to prevent intrusion or stagnation of rain water in conduits.
- **Shock and Vibration**
Select an installation site with minimum shock and vibration (although the transmitter is designed to be relatively resistant to shock and vibration).

3.2 Installation Procedure

This section provides the information concerning installation of the transmitter for safe operation. It provides the procedures and instruction for mounting, transmitter functions, and installation in specific applications.

3.2.1 Mount the Transmitter Using Mounting Brackets

Mount the transmitter using mounting brackets as shown in figure below:

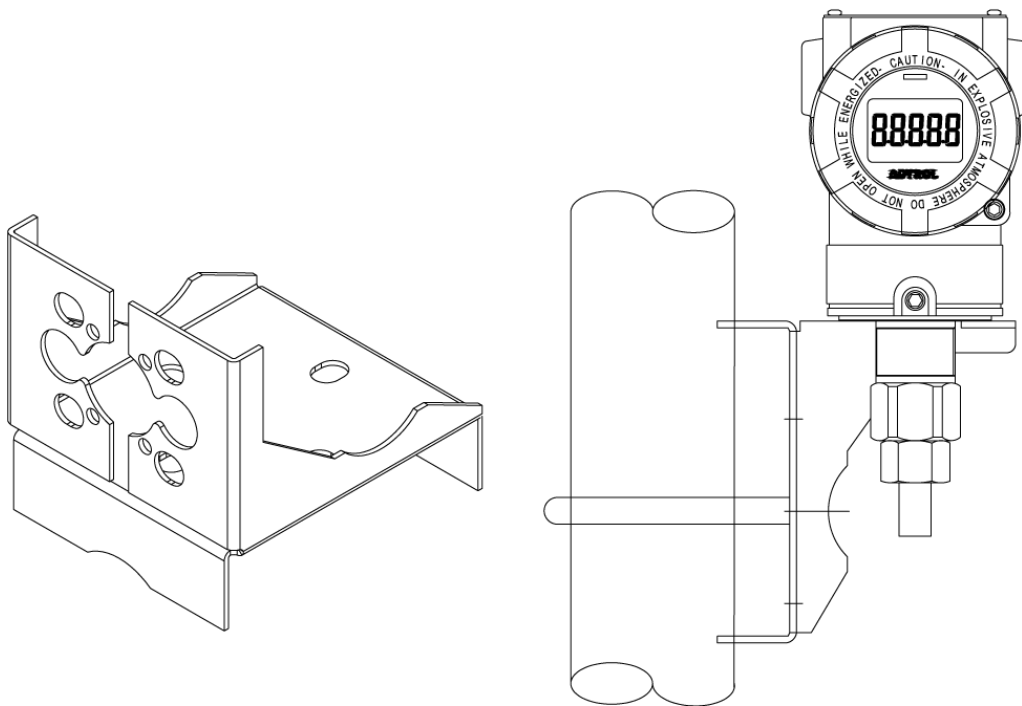

2" Pipe Mounting Bracket
Model: Angle Type

3.2.2 Housing Rotation

To improve the visibility of LCD display the housing of the Transmitter can be rotated as follows:

- Loosen the housing screw
- Rotate housing to the desired location up to 360°
- Re-tighten the housing screw

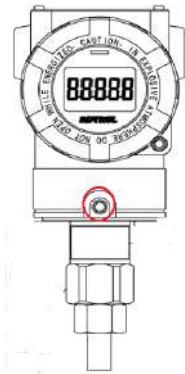

3.2.3 Terminal Side of Transmitter

Mount the transmitter so the terminal side is accessible to the operator.

3.2.4 LCD Display Rotation

If the device cannot be operated in a vertical position you can turn the digital display to make it easier to read. To do this, proceed as follows:

Unscrewing the two screws on either side of the LCD screen allows the screen to be rotated 90° clockwise or counter clockwise. An integral indicator can be installed in the following three directions.



3.2.5 Conduit Installation

If all connections are not sealed, excess moisture accumulation can damage the transmitter. Make sure to mount the transmitter with the electrical housing positioned downward for drainage. To avoid moisture accumulation in the housing, install wiring with a drip loop, and ensure the bottom of the drip loop is mounted lower than the conduit connections or the transmitter housing.

i NOTE

Conduit thread must be engaged with a minimum of 5 thread connections

3.2.6 Mounting Requirements

Impulse piping configurations depend on specific measurement conditions.

3.2.7 Liquid Flow Measurement

- Place the taps to the side of the line to prevent sediment deposits on the transmitters process isolators
- Mount the transmitter beside or below the taps so gases can vent into the process line
- Mount drain/vent the valve upward to allow gases to vent

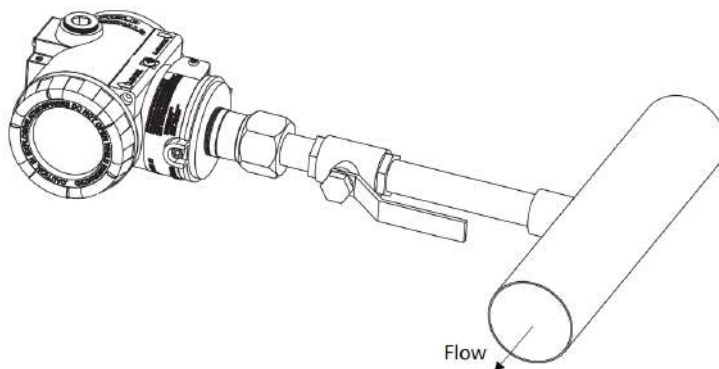

3.2.8 Gas Flow Measurement

- Place the taps in the top or side of the line
- Mount the transmitter beside or above the taps so liquid will drain into the process line

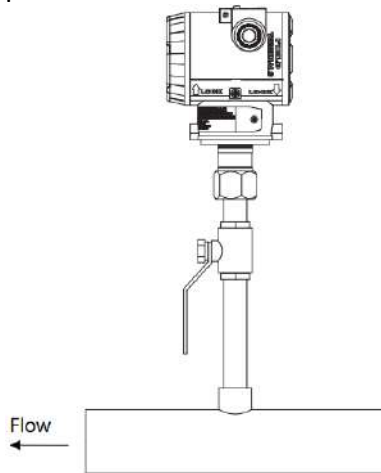

3.2.9 Steam Flow Measurement

- Place taps to the side of the line
- Mount the transmitter below the taps to ensure that the impulse piping will stay filled with condensate
- In steam service above 250°F (121°C), fill impulse lines with water to prevent the steam from contacting the transmitter directly and to ensure accurate measurement at start-up

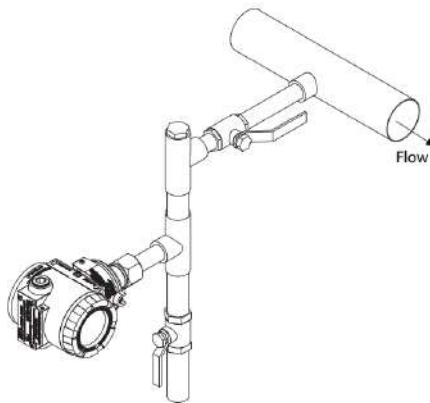

i NOTE

For steam or other elevated temperature services, it is important that temperatures at the process connection do not exceed the transmitters process temperature limits

3.2.10 Zero Trim after Installation

- Sensor Zero Trim should be done immediately after transmitter is installed because zero point can shift due to mounting status of the sensor pick up.
- For sensor zero trim, make input pressure of transmitter zero prior to initiating zero trim calibration. Any sensor trim done in field must be carried out after final installation of transmitter. Also, if applying external pressure to the transmitter make ensure that the display is sufficiently stabilized (after approximately 10 to 15 seconds), before initiating any trim function.
- There are 3 recommendations for making input pressure “Zero”.
 - One is to apply a “Zero” pressure source (mandatory for absolute pressure models)
 - Second is to apply equal pressure on both HP and LP ports (DP models only)
 - The third option is to open equalizing valve of manifolds installed and venting to atmospheric pressure (allowed only for Gauge & DP type models only)
- Sensor zero trim can be performed using an external HHC (Handheld calibrator), PC or PDA configurator, and/or using Zero/Span local push buttons provided on the transmitter.
- When using local push buttons refer to section 5.3 of this manuals for detailed instructions. If using an external HHT or HART® PC configurator, refer to the user manual supplied by the third-party supplier.

4 Electrical Connection

This section covers the all electrical connection requirement. Electrical connection of the device must be carried out by trained, qualified specialists authorized to perform such work by the installation site.



WARNING

- Connect all electrical cables when the power is switched off. If the device does not have switch-off elements, then, overcurrent protection devices, lightning protection and/or energy isolating devices must be provided by the customer.
- The device must be grounded to a spot in accordance with regulations in order to protect personnel against electric shocks.



NOTE

- When using the measuring device in hazardous areas, installation must comply with the corresponding national standards and regulations and the Safety Instructions or Installation or Control Drawings.

4.1 Grounding of Measuring Device

Provide for proper grounding (earth ground) at designated points (external or internal). There is a ground terminal provided on the inside and the outside of the terminal box. Either one of these terminals may be used for grounding the transmitter.

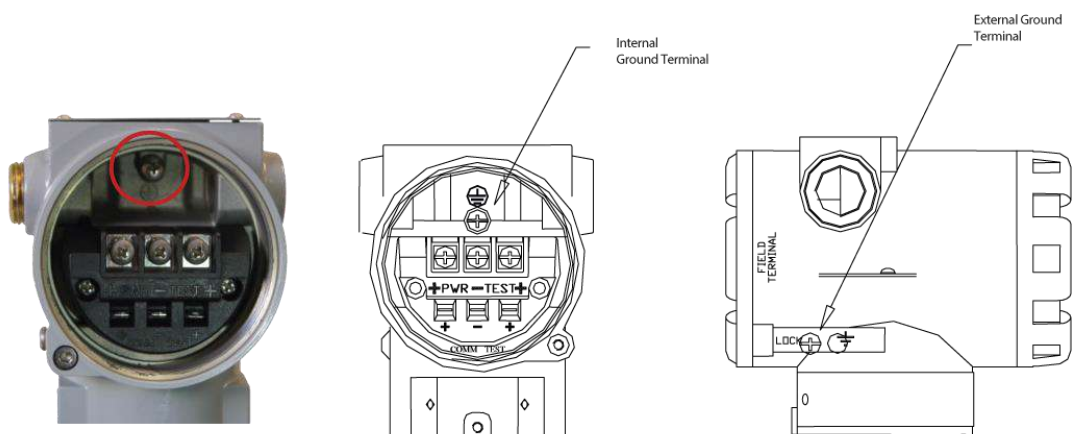

4.2 Power Supply Connection

- Remove the housing cover on terminal compartment side. Do not remove the cover in explosive atmospheres when the circuit is alive. Signal wiring supplies all power to the transmitter.
- Connect the positive lead to the terminal marked (+) and the negative lead to the terminal marked (pwr/comm-). Do not connect powered signal wiring to the test terminals. Power could damage the test diode.

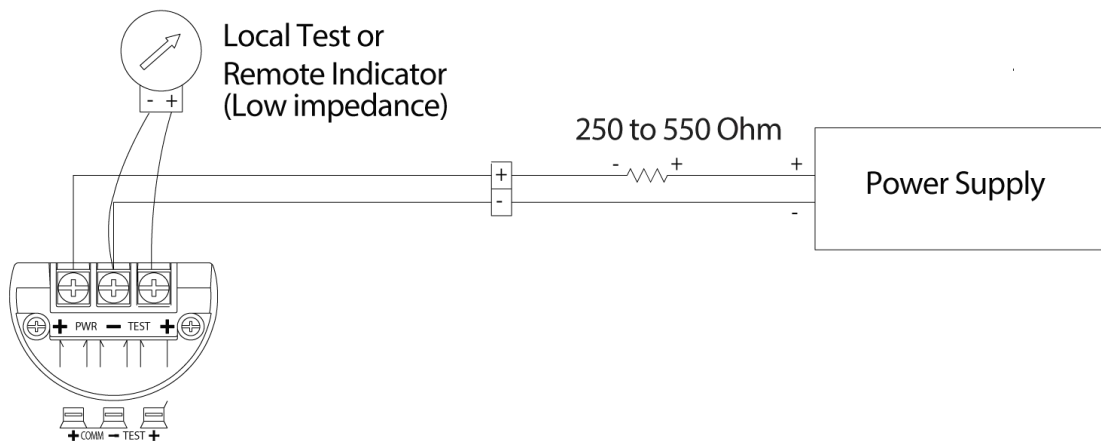

4.3 Connection to the HART Handheld Communicator

HART Communicator requires a loop resistance between 250Ω and 550Ω.

Transmitter operates on 11.9 –45 VDC.

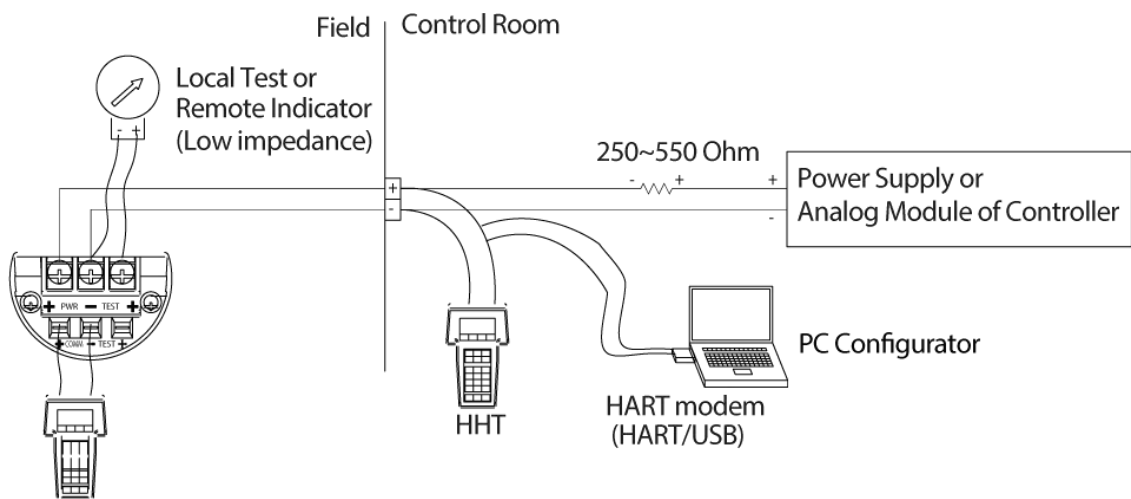

Power Supply for 4 to 20mA HART

The transmitter operates on 12 to 45VDC. The 250 Ω resistor require to communicate with Field Communicator.

Load Limitation

Maximum loop current is 24mA,

Load resistance R,

$$R = (E - 11.9) / 0.022 \quad (E = \text{Power Supply Voltage})$$

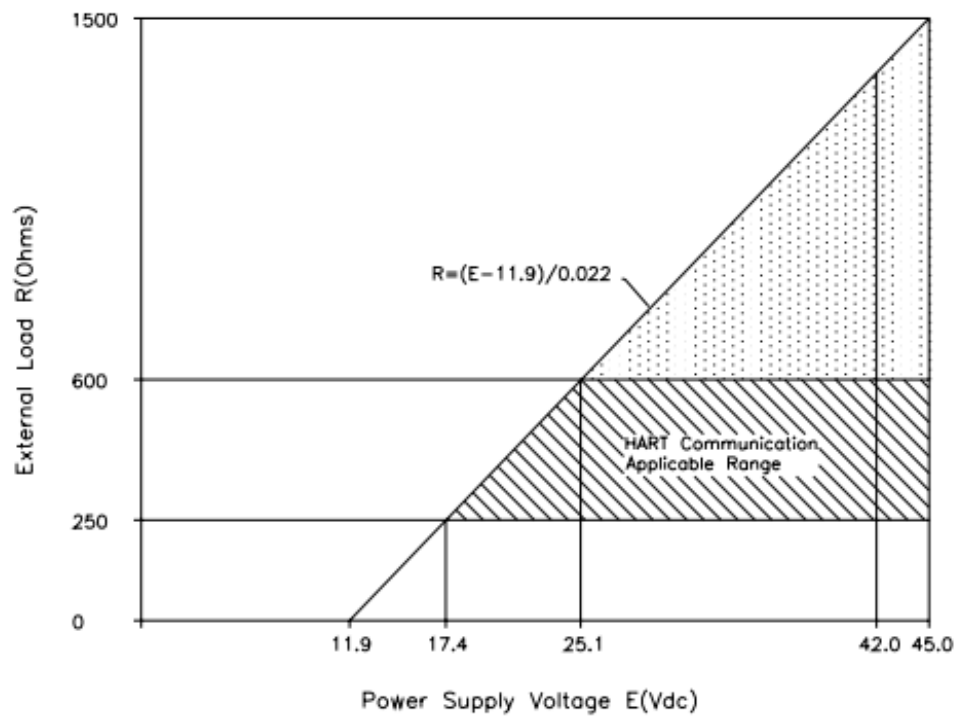

5 Operation

This section covers operation techniques and guidelines.

5.1 Local Operation and Display

Tek-Bar 3120A is available with the optional display. Parameters setting of transmitters are done by using LCD display and buttons. The displays indicate output and diagnostic messages.

5.1.1 Operation Without Display

If LCD display is not available, the use HART for communication. (Refer section 5.5)

5.1.2 Operation With LCD Display

The local display enables you to read all important parameters directly at the measuring point and configure the device using the function matrix. The LCD display indicates output and diagnostic messages on display. The LCD display features a two-line display with 5-digit. The first line displays measured value and the second line display the engineering units.

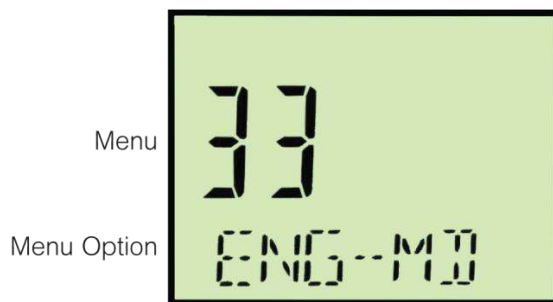

5.2 Basic Setup

5.2.1 Failure Mode Alarm

The Tek-Bar 3120A Transmitter automatically and continuously perform self-diagnostic functions. If the self-diagnostic routines detect a failure the transmitter drives its output outside of the normal saturation values. The transmitter will drive its output low or high based on the position of the failure mode alarm jumper.

Level	4 to 20mA Saturation	4 to 20mA alarm
Low/Down	3.9mA	$\leq 3.75\text{mA}$
High/Up	20.8mA	$\geq 21.75\text{mA}$

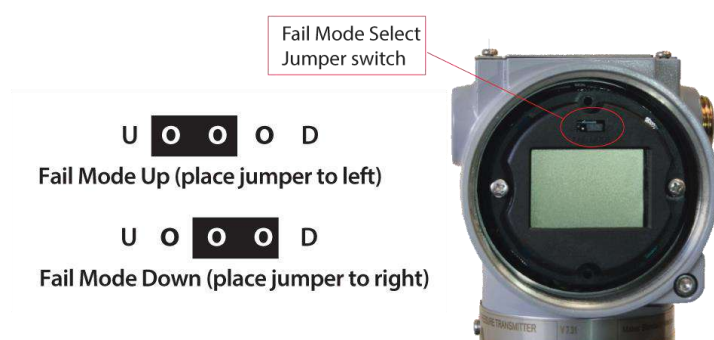

Fail Mode Selection (Fail High/UP or Low/DOWN) can be configured using the appropriate jumper switch provided on the LCD module or DIP switches included on the Main CPU Module. For units provided with a LCD module one can select desired fail-safe mode directly from the jumper switch included in the front display and this setting overrides the DIP settings on the back-end main CPU module. However, in case of blind units select your required DIP switch settings from the DIP switch labelled (2) marked on the main CPU board.

Selected Fail Mode	Jumper status on LCD and DIP Switch (2) on CPU Module		DIP Switch (2) Setting on CPU Module
	CPU Module	LCD Module	CPU Module
Fail Down	Down	D	Down
Fail Up	Down	U	Up
	Up	D and U	

5.2.2 Damping Time

The “Damp” command introduces a delay in the micro-processing which increases the response time of the transmitter; smoothing variations in output readings caused by rapid input changes. Determine the appropriate damping setting based on the necessary response time, signal stability, and other requirements of the loop dynamics within your system. The default damping value is 1 seconds and it can be set to any of ten pre-configured damping values between 0 and 60 seconds.

5.2.3 Security Jumper (EEPROM-Write Protect)

Protects the against a change of Configuration Parameter of the transmitter to Write protect jumper. The EEPROM (Electrically Erasable Programmable ROM) restores various configuration variables in the transmitter. To protect the change configuration variable data in software, on the hardware side there is Write-Protect mode and jumper switch selected and segmented "EEP-Write DIS / EN" in the main CPU module. Thus, if you connect the jumper to DIS you can't change configuration data in EEPROM. When you connect the jumper to EN you can change the configuration data in EEPROM. If there is no connected jumper, it is classified EN. At the factory before shipment, it is configured "EN".

You can prevent changes to the transmitter configuration data with the write protection jumper. Security is controlled by the security (write protect) jumper located on the electronics board or LCD display. Position the jumper on the transmitter circuit board in the “ON” position to prevent an accidental or deliberate change of configuration data. If the transmitter writes protection jumper is in the “ON” position, the transmitter will not accept any “Writes” to its memory. Configuration changes, such as digital trim and re-ranging, cannot take place when the transmitter security is on.

5.2.4 Loop Test

The Loop Test verifies the output of the transmitter, the integrity of the loop, and the operations of any recorders or similar devices installed loop. Perform the following procedure for a loop test.

- Connect a reference meter to the transmitter.
- Select the loop test of HHT and operate the loop test.
- Select output current (4mA/20mA/etc.)
- If the readings match, then the transmitter and the loop are configured and functioning properly.

If the readings do not match, then you may have the current meter attached to the wrong loop, there may be a fault in the wiring, the transmitter may require an output trim, or the electrical current meter may be malfunctioning.

5.3 Configuration

5.3.1 Zero and Span Magnetic Buttons

The zero and span adjustment is a way of configuring the transmitter when the communicator is not available.



The local push button allows for local configuration of basic parameters of a transmitter in absence of a HHT or external HART® enabled configurators.

To re-range, the transmitter using the span and zero buttons, perform the following procedure.

The top nameplate (right side only) is located in the upper part of the transmitter. Slide the nameplate anti-clockwise (slightly until the Zero/Span button is visible and fully accessible.

A single operation of individual buttons (labelled Zero/Span respectively) will initiate a zero/span configuration process as found in conventional transmitters requiring an external pressure source. However, as these are smart transmitters most configuration functions such as zero trim, zero adjustment, selecting units, re-ranging (or setting URL/LRL), damping time, display resolution, LCD preference etc can be done without any external pressure source or HHT.

Setting URL/LRL Using External Pressure Source

A. Zero (or LRL) Calibration

Apply the desired 4 mA pressure value to the transmitter. Apply required LRL pressure on the transmitter over 10 second and press “Zero” button over 5 seconds until “Zero” is displayed on LCD display. Once the input pressure for LRL value is stabilized press the “zero” button again until display shows “-ZE- “in LCD window. Release button and wait 2-3 seconds for transmitter to calibrate the LRL value (applied as PV input). If Zero Procedure was incorrectly performed display will show “ZR-Er” error code indicating failure and possible LRL setting out of sensor range capabilities.

B. Span (or URL) Calibration

Apply the desired 20 mA pressure value to the transmitter. Apply required URL pressure on the transmitter over 10 second and press “Span” button over 5 seconds until “Span” is displayed on LCD display. Once the input pressure for URL value is stabilized press the “Span” button again until display shows “-SP-” in LCD window. If Span calibration is incorrect display will prompt failure by displaying “SPEr” error code* indicating failure and possible URL setting out of sensor range capabilities.

5.3.2 Advance Configuration Via Push Button.

This includes re-ranging of transmitters (Set URL/LRL) without an external pressure source.

To access advanced configuration and enter programming menu press both (Zero + Span) buttons simultaneously for 5 seconds. When display reads “Menu” release both push buttons immediately. This will put user into top of main programming menu indicated by message “1-TRIM” on display. To navigate through main menus and /or sub-menus:

- Use (Zero) button to scroll down a menu (or sub-menu if active).
Example press/release (Zero) to scroll down from main menu 1-Trim > 2-Setup > 3-LCD > 1-Trim > 2-Setup etc. or from an active sub-menu press/release (zero) to scroll down within a sub menu example 21-Units > 22-URL > 23-LRL > 24-Damping > 21- Units > 22-URL etc.
- Use (Span) button to enter a specific sub-menu or data input function.
Example pressing (Span) button from main menu will put user into sub-menu “11>Zero Trim”. Releasing and Pressing (Span) button again will initiate Zero Trim configuration or release and pressing (Zero) button instead will increment user down to sub-menu “12>Zero ADJ”.
- Within an active sub-menu use of (Span) button also acts as a key to allow user to save changes and exit programming mode.
- For moving back to previous menu press (Zero + Span) button together. During numeric value entry mode use (Zero + Span) button together to save numeric data inputted and exit from programming menu.

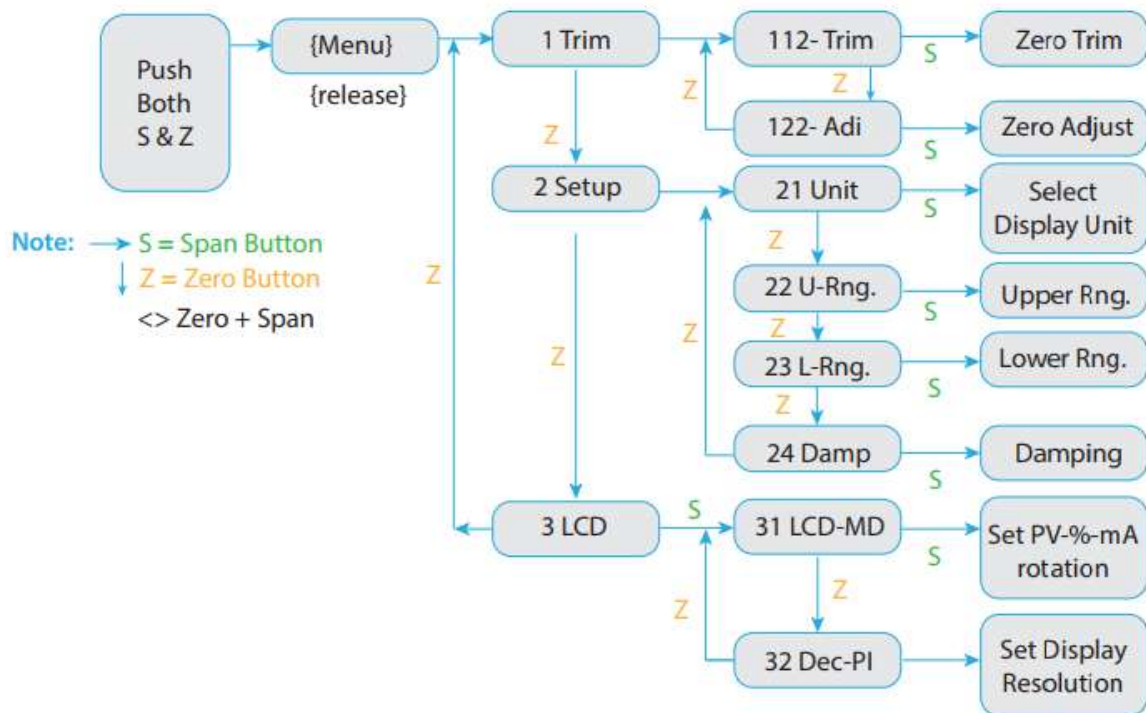

5.3.3 Steps to Input Numeric Data Value

Specific functions that need users to input a numerical value are found under sub-menu

- 12 Zero Adjustment
- 22 Change Upper Range Value
- 23 Change Lower Range Value
- 24 Damping Second

Due to limited flexibility with only 2 push buttons available for configuration, it is not possible to directly input numeric values within this sub-menu. Instead, the correct sequence requires user to first set an increment (10x) rate e.g. 0.01, 0.1, 1.0, 10, 100, 1000 etc and then proceed with changing numeric value by the set rate increment. For example, to input a numeric value as “3810” from existing the displayed value of “0000”:

- First Set increment rate as “1000”
- Increase display “0000” value 3 times in steps of 1000 till it reads “3000”
- Then set increment rate again as “100”
- Increase 8 times in steps of 100 till display reads “3800”
- Set increment rate again as 10
- Increase 1 time for a step change of 10 till display reads 3810

When activating these sub-menus (by pushing down & releasing (Span) button from within its active menu the display will automatically prompt for "Set Inc" message.

1. To select an increment rate press (Zero) button when "Set Inc" message is displayed on LCD sub-menu. Release (Zero) button when display value changed. Each subsequent (Zero) push-release key stroke will shift display decimal point to left. Example when display shows "Set Inc" 0.01. Subsequently for every push-release keystroke of (Zero) button the display will cycle from >0.1>1.0>10>100>1000>0.1>1.0 etc.
2. Once desired "Set Inc" (viz. 0.1, 1, 10, 100 etc) increment rate is set push the (Span) button to accept and enable set numeric "Value" mode. When executing (Span) button from "Set Inc" menu the LCD display will typically show the last saved numerical value along with a "Value" message on second line indicating that user can now initiate changes by incrementing or decrementing numeric value.
3. From within "Value" menu press either (Zero) or (Span) button (not both) will allow the numeric value to increment (Zero) or decrement (Span) by the "Set Inc" value selected by user in the previous step (2).
4. After desired numeric value is displayed, push down on (Zero + Span) buttons together to accept new data inputted and this will bring user back to menu.
5. Repeat steps (1) through (3) detailed above until the final numeric value required is displayed under set "Value" Menu.
6. To store final numeric value to EEPROM push (Zero + Span) button twice to save and exit. Pushing (Zero + Span) once from "Value" menu will bring user back to "Set Inc" menu step (1). However, pressing (Zero + Span) buttons together second time (from "Set Inc" menu). Release button when screen shows "Inc Ok" message after which it will save the last numeric value inputted and bring user back to measurement mode.
7. If successful display will read -DONE- else "BR-ERR" to indicate failure. If the display shows "RANGOVR" it indicates numerical value inputted is out of specification.

5.3.4 Push Button Sequence for Each Programming Sub-Menu

5.3.4.1 Zero Trim (Sub Menu 11)

1. Enter programming menu by pushing both (Zero + Span) button together for 5 seconds. Release buttons when LCD displays menu and display will automatically change to “1 TRIM” confirming access into programming menu.
2. Push (Span) button when “1 TRIM” message appears to enter 11 Z-Trim sub-menus.
3. To execute the zero trim sub-menu function push (Span) button when 11 Z-TRIM message appears on LCD display.

NOTE

Make sure process input to the transmitter is at true zero else this may create an incorrect zero offset. If a wrong zero is suspected, execute zero trim again ensuring the proper steps & correct Zero PV input is applied to transmitter

5.3.4.2 Zero Adjustment (Sub-Menu 12)

Example used to show changing the PV value as 14.

- Enter programming menu by pushing both (Zero + Span) button together for 5 seconds. Release buttons when LCD displays menu and display will automatically change to “1 TRIM” confirming access into programming menu.
- Push (Span) button when 1 TRIM message appears to enter 11 Z-Trim sub menus. Push (Zero) to change display to menu 12 Z-ADJ.
- To execute the zero-adjustment function push (Span) button when 12 Z-ADJ message appears on LCD display.
- When “Set Inc” message appear, push the zero button repeatedly until 10.0 message appears on LCD. And then push (Span) button to accept and proceed into input “Value” menu.
- When “Value” message appears on display, increment forward (Span) or decrement backward (Zero) to set the LCD value to “10.0”. The LCD display will increment or decrement by factor of 10 which is the (Set Inc Value) selected in previous menu. Once desired base value of “10” is displayed push (Zero + Span) button to accept new value and “Set Inc” message appears upon which release buttons.
- From menu where “Set Inc” message appears again, change the LCD value to 1.0 by pushing (Zero) button once and then push (Span) button to enter input “Value” menu.
- Here push (Span) or (Zero) to increment or decrement by Set Inc (1) until display reads “14”. Push (Zero + Span) button after LCD value is changed to 14.0 and release both button when display reads “Set Inc”.
- To save the numeric value of 14 set from previous steps push (Zero + Span) buttons from the “Set Inc” menu to save and exit. Display will show “Inc Ok” at which point release buttons.

- Display with show “-DONE- “confirming changes has been accepted and then default back into measurement mode. This completes the Zero adjustment configuration.
- If display shows “BT-ERR” instead of “-DONE- “repeat all steps once again.
- If display shows “ADJ-U” or “ADJ-L” the inputted numerical value is out of specification for zero adjustment range for the supplied range codes.

5.3.4.3 Change Units (Sub-Menu 21) – Example Set Units to “psig”

- Enter programming menu by pushing both (Zero + Span) button together for 5 seconds. Release buttons when LCD displays menu and display will automatically change to “1 TRIM” confirming access into programming menu.
- Push (Zero) button when 1 TRIM message appears on LCD. Release button when display changes to 2 SETUP.
- To move into sub menu push (Span) button when 2 SETUP message appears on display. Release button when 21 UNIT message is displayed.
- You are now in the change units sub menu. To execute this function push (Span) button when 21 UNIT message appears on display. Release button when display changes to 211 (xxx) where “ xxx “ is the last units (e.g. bar, kpa, “H₂O etc) saved previously.
- Push/release (Zero) button repeatedly to toggle through all available units. When desired “psig” units are displayed save and exit by pushing (Span) button.

5.3.4.4 Change URL/ Upper Range Value (Sub-Menu 22)

- Enter programming menu by pushing both (Zero + Span) button together for 5 seconds. Release buttons when LCD displays menu and display will automatically change to “1 TRIM” confirming access into programming menu.
- Push (Zero) button when “1 TRIM” message appears on LCD. Release button when display changes to “2 SETUP”.
- To move into sub directory push (Span) button when “2 SETUP” message appears on display. Release button when display changes to “21 UNIT” message.
- Push (Zero) button to move down to sub-menu 22. When display shows “22 U-RNG” release button. You are now in URL sub menu.
- To execute this function push (Span) button when “22 U - RNG” message appears on display. Release button when display changes to 221 (xxxx) where xxxx is last configured URL value saved.

5.3.4.5 Change LRL/ Lower Range Value (Sub-Menu 23)

- Enter programming menu by pushing both (Zero + Span) button together for 5 seconds. Release buttons when LCD displays menu and display will automatically change to “1 TRIM” confirming access into programming menu.
- Push (Zero) button when “1 TRIM” message appears on LCD. Release button when display changes to “2 SETUP”.
- To move into sub directory push (Span) button when “2 SETUP” message appears on display. Release button when 21 UNIT message is displayed.
- Push (Zero) button to move down to sub-menu 22. When display shows “22 U-RNG” release button.
- Push (Zero) button to move down to sub-menu 23. When display shows “23 L-RNG” release button.
- You are now in change LRL sub menu. To execute this function push (Span) button and release when “231 xxxx” message appears on display. Where xxxx is last configured LRL value saved.



Note

When setting URL/LRL numeric data ensure values being inputted fall within the allowed minimum/maximum specifications published for the installed sensor range code. Only if display shows “-DONE-“ will the transmitter update its stored configuration & accept the new values. If out of limits the transmitter will reject values entered and default to previous saved values after displaying a “RANG OVR” error message

5.3.4.6 Changes Damping Value (Sub-Menu 24)

- Enter programming menu by pushing both (Zero + Span) button together for 5 seconds. Release buttons when LCD displays menu and display will automatically change to “1 TRIM” confirming access into programming menu.
- Push (Zero) button when “1 TRIM” message appears on LCD. Release button when display changes to “2 SETUP”.
- To move into sub directory push (Span) button when “2 SETUP” message appears on display. Release button when 21 UNIT message is displayed.
- Push (Zero) button to move down to sub-menu 22. When display shows “22 U-RNG” release button.
- Push (Zero) button to move down to sub-menu 23. When display shows “23 L-RNG” release button.
- Push (Zero) button to move down to sub-menu 24. When display shows “24 DAMP” release button.
- You are now in change damping sub menu. To execute this function push (Span) button when “24-Damping” message appears on display. Release button when display changes to 241 (xxxx) when xxxx is last configured damping value saved.

5.3.4.7 Change LCD Mode (Cyclic or Fixed Display) (Menu 31)

- Enter programming menu by pushing both (Zero + Span) button together for 5 seconds. Release buttons when LCD displays menu and display will automatically change to “1 TRIM” confirming access into programming menu.
- Push (Zero) button when “1 TRIM” message appears on LCD. Release button when display changes to “2 SETUP”.
- Push (Zero) button and release when display changes to “3 LCD”.
- To move into sub directory push (Span) button after “3 LCD” message appears on display. Release button when 31 LCD-MD messages is displayed.
- To enter this sub-menu push (Span) button and release when display changes to 311. Bottom line of display will show current mode setting e.g. NOR-RO, NOR-PV etc.
- Push (Zero) button to cycle through available mode options and select desired LCD rotation mode. Options are:
NOR-RO (rotate all PV, %, mA), NOR-PV (Fixed PV),
NOR-% (Fixed %), NOR-mA Fixed,
ENG-RO, ENG-PV, ENG-% or ENG-mA.
- Push (Span) to save changes and EXIT programming mode.

5.3.4.8 Change LCD Resolution (Sub-Menu 32)

- Enter programming menu by pushing both (Zero + Span) button together for 5 seconds. Release buttons when LCD displays menu and display will automatically change to “1 TRIM” confirming access into programming menu.
- Push (Zero) button when “1 TRIM” message appears on LCD. Release button when display changes to “2 SETUP”.
- Push (Zero) button and release when display changes to “3 LCD”.
- To move into sub directory push (Span) button after “3 LCD” message appears on display. Release button when 31 LCD-MD messages are displayed.
- Push (Zero) button to move down one sub-menu and release button when “32-DEC-PL” message is displayed.
- Push (Span) button to execute this sub-function. Release button when the display changes to 0.0. Note 0.0 will be displayed on the first line of LCD. The second line will indicate mode options viz. AUTO, 5-0, 4-1 etc
- All available resolution modes are listed below in Table.

Model	Description	Max. Value
AUTO	Auto ranging of display	99999
5-0	None decimal place	99999
4-1	Display one decimal place	9999.9
3-2	Display two decimal places	999.99
2-3	Display three decimal places	99.999
1-4	Display four decimal places	9.9999

- Push (Zero) to cycle through display options i.e. AUTO, 5-0, 4-1, 3-2, 2-3 and 1-4 and once desired resolution is displayed push (Span) to save and exit.

5.4 Menu Tree

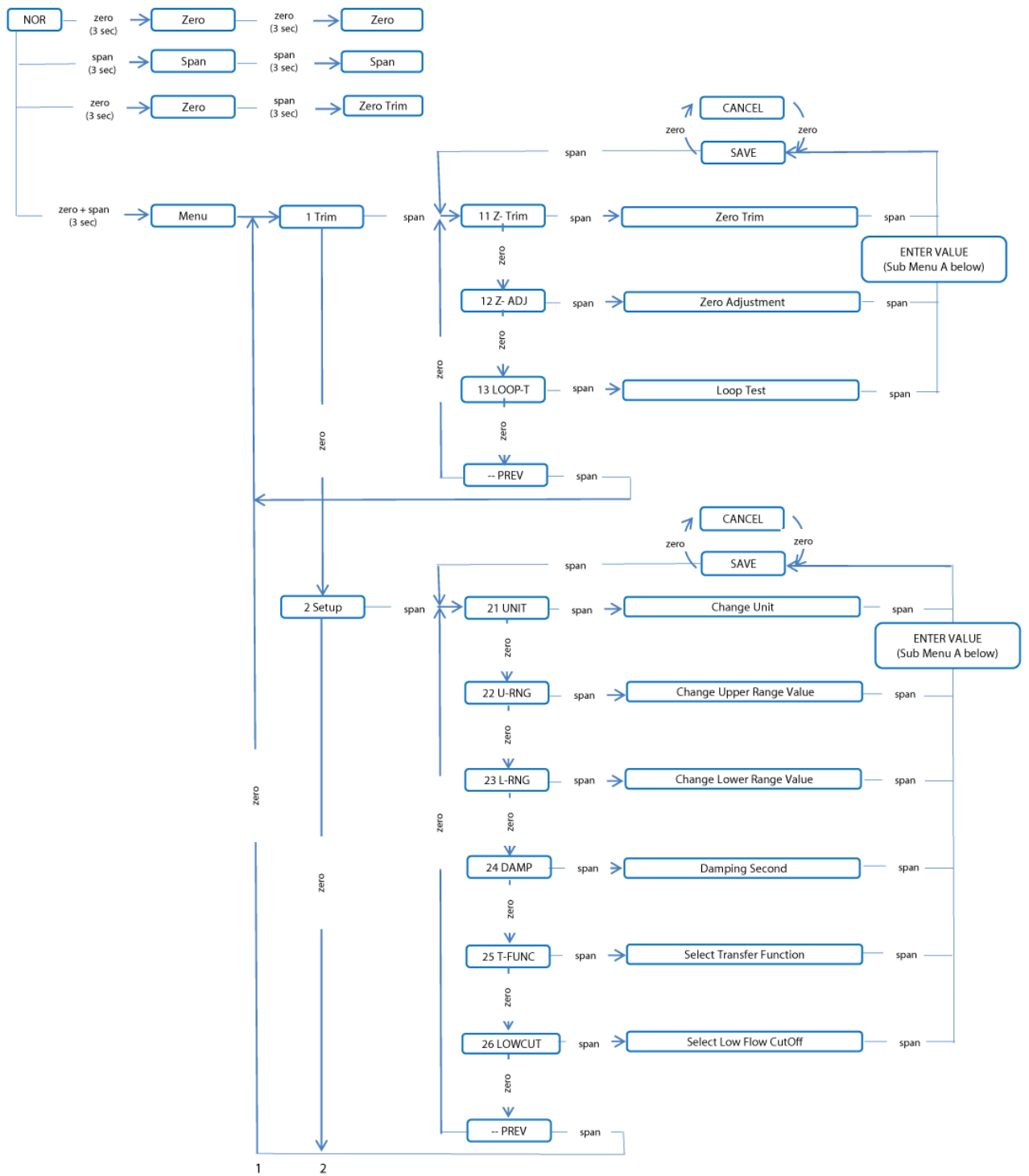

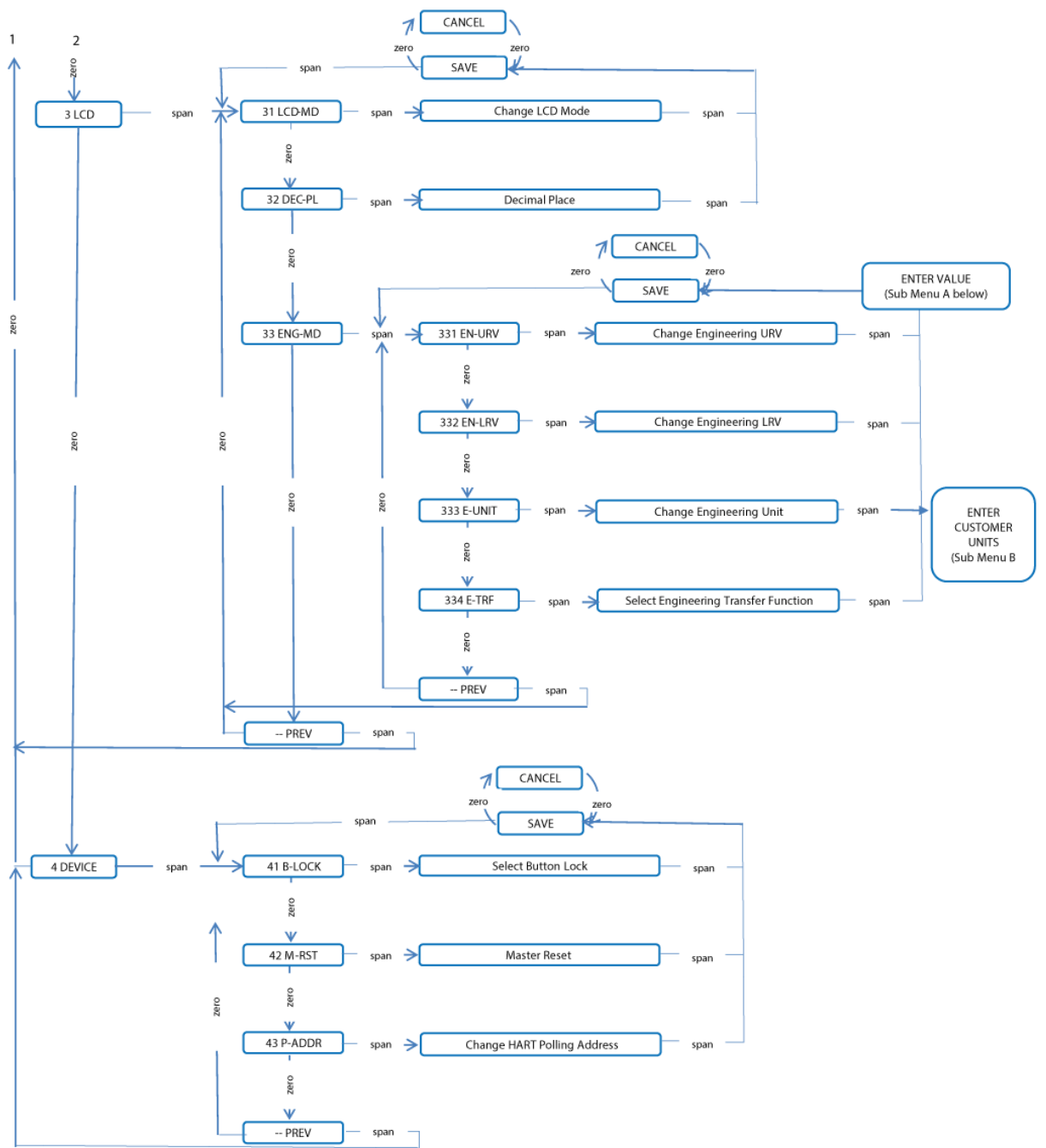

5.5 Handheld Communicator

If custom display is not available, then configure transmitter parameter using communicator. Decimal point position, Upper range value, Lower range value, Engineering units are configured. See the below flow chart.

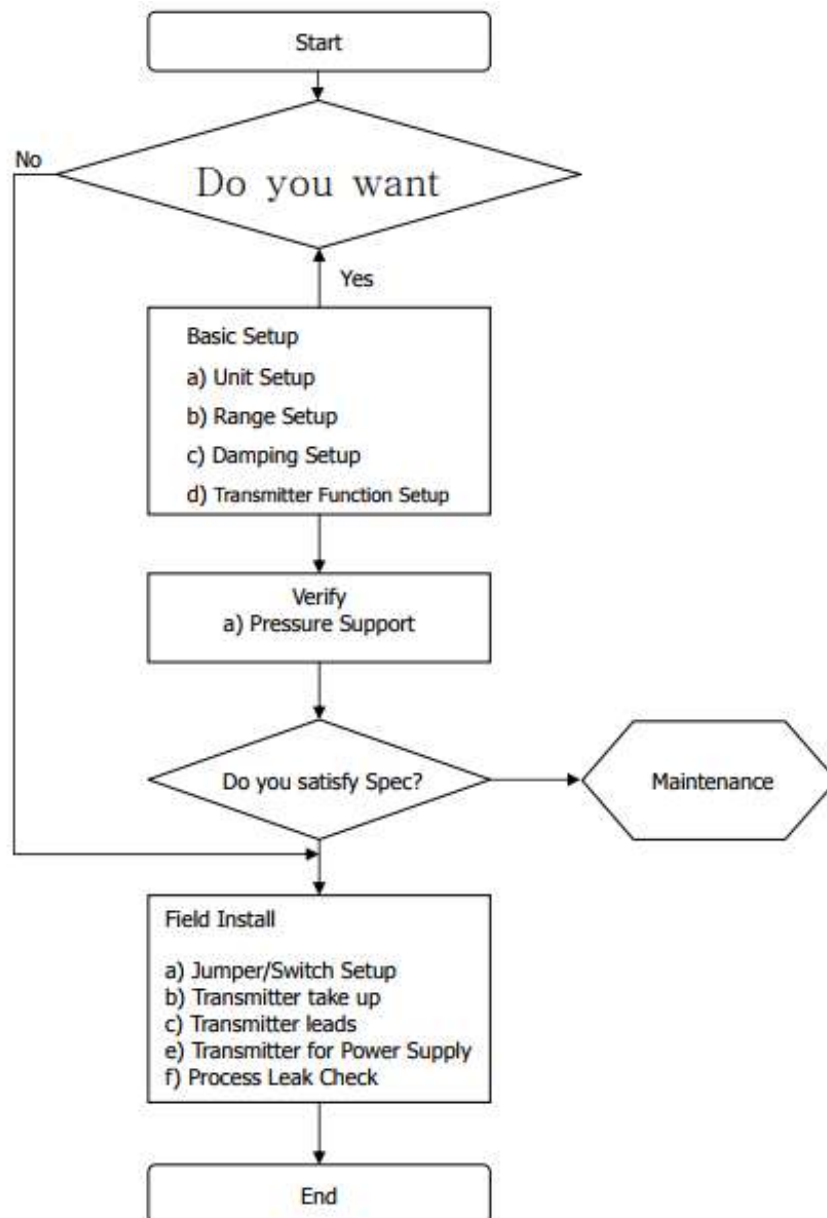

6 Troubleshooting

This section provides troubleshooting techniques for most common operating problems.

6.1 Hardware Diagnostics

If you suspect a malfunction despite the absence of any diagnostic messages on the HHT, follow the table below to verify that the transmitter hardware and process connections are in good working order:

Symptom	Potential Source	Corrective Action
Transmitter Does Not Communicate with HART Communication	Loop Wiring	Check for a minimum of 250 ohms resistance between the power supply and HHT.
		Check for adequate voltage to the transmitter. The transmitter always requires 11.9 to 45 Vdc.
		Check for intermittent shorts, open circuits, and multiple grounds
High Output	Sensor Input Failure	Connect HHT and enter the Transmitter test mode to isolate a sensor failure.
	Loop Wiring	Check for dirty or defective terminals, interconnecting pins, or receptacles.
	Power Supply	Check the output voltage of the power supply at the transmitter terminals. It should be 11.9 to 45 Vdc in spite of loop scale
	Electronics Module	Connect HHT and enter the Transmitter test mode to isolate module failure. Check the sensor limits to ensure calibration adjustments are within the sensor range.

Symptom	Potential Source	Corrective Action
Erratic Output	Loop Wiring	Check the output voltage of the power supply at the transmitter terminals. It should be 11.9 to 45 Vdc.
		Check for intermittent shorts, open circuits, and multiple grounds.
		Check for proper polarity at the signal terminals.
		In case measuring electric current while digital communication, output appear around $\pm 0.013\text{mA}$
	Electronics Module	Connect HHT and enter the transmitter test mode to isolate an electronics mode failure.
Low Output or No Output	Sensor Element	Connect HHT and enter the Transmitter test mode to isolate the sensor failure.
		Check the PV to see if it is out of range.
	Loop Wiring	Check for adequate voltage to the transmitter. The transmitter always requires 11.9 to 45 VDC.
		Check for intermittent shorts, open circuits, and multiple grounds.
Check polarity of signal terminal		
		Check the loop impedance.
	Electronics Module	Connect HHT and check the sensor limits to ensure calibration adjustments are within the sensor range.

6.2 Error Codes

Tek-Bar 3120A Explosion-Proof Gauge Pressure Transmitter LCD Display error codes.

Message	Description
ADJ-U	Out of Zero setting value when Zero Adj function using button (upper side)
ADJ-L	Out of Zero setting value when Zero Adj function using button (lower side)
ZERO	Initial message in using the Zero button
SPAN	Initial message in using the Span button
BT-ERR	Button Input Sequence Error
P-LOCK	Button Input Error when Protect Locked
ZT-ERR	Setting Limit (10%) Error when in Zero Trim
-TR-	Zero Trim Complete
ZR-ERR	Setting Limit Error when executing the Zero button function
SP-ERR	Setting Limit Error when executing the Span button function
-ZR-	Zero button function Complete
-SP-	Span button function Complete
-ZA-	Zero Adjustment done
-DONE-	Setting Done using button
RNGOVR	Setting Limit error when executing other setting function
LCD_OV	Over figure values for LCD
SCD-ER	Sensor Code Error
F-RST	Flash Setting Data Rese
F-LOCK	While Flash Setting Data Reset, Protect Locked
F-FAIL	Flash Setting Data Reset Failure
-FR-	Flash Reset Done
A-RST	Analog EEPROM Initializing Start
A-STOR	Analog EEPROM Whole Write
A-FAIL	Analog EEPROM Whole Write Failure



TEKMATION LLC reserves the right to change the designs and/or materials of its products without notice. The contents of this publication are the property of TEKMATON LLC and cannot be reproduced by any other party without written permission. All rights reserved. Copyright © 2020 TEKMATON LLC
DOC-TEKTROL/MNL/200666/9/1204/01
TEKMATION LLC



www.tek-trol.com

Tek-Trol is a fully owned subsidiary of TEKMATON LLC. We offer our customers a comprehensive range of products and solutions for process, power and oil & gas industries. Tek-Trol provides process measurement and control products for Flow, Level, Temperature & Pressure Measurement, Control Valves & Analyzer systems. We are present in 15 locations globally and are known for our knowledge, innovative solutions, reliable products and global presence.

Tek-Trol LLC

796 Tek Drive Crystal Lake, IL 60014,
USA
Sales: +1 847-655-7428

Tek-Trol Solutions BV

Florijnstraat 18, 4879 AH Etten-Leur,
Netherlands
Sales: +31 76-2031908

Tek-Trol Middle East FZE

SAIF Zone, Y1-067, PO BOX No.
21125, Sharjah, UAE
Sales: +971-6526-8344

Support: +1 847-857-6076

Email: tektrol@tek-trol.com

www.tek-trol.com

Flow | Level | Temperature | Pressure | Valves | Analyzers | Accessories | TekValSys