



# ***TEK-SOUND 4200A***

## ***Explosion Proof Ultrasonic Level Transmitter***

---

### **Instruction Manual**

Document Number: IM-4200A



[www.tek-trol.com](http://www.tek-trol.com)

---

**NOTICE**

Read this manual before working with the product. For personal and system safety, and for optimum product performance, make sure you thoroughly understand the contents before installing, using, or maintaining this product.

For technical assistance, contact

Customer Support

796 Tek-Drive

Crystal Lake, IL 60014

USA

Tel: +1 847 857 6076, +1 847 655 7428

**© COPYRIGHT Tek-Trol LLC 2016**

No part of this publication may be copied or distributed, transmitted, transcribed, stored in a retrieval system, or translated into any human or computer language, in any form or by any means, electronic, mechanical, manual, or otherwise, or disclosed to third parties without the express written permission. The information contained in this manual is subject to change without notice.

## Table of Contents

<b>1</b>	<b>Safety Instructions</b>	<b>2</b>
1.1	Intended Use	2
1.2	Safety Instructions from the Manufacturer	2
1.2.1	Disclaimer	2
1.2.2	Product Liability and Warranty	2
1.2.3	Information Concerning the Documentation	2
1.3	Safety Precautions	2
1.4	Packaging, Transportation, and Storage	3
1.4.1	Packaging	3
1.4.2	Transportation	4
1.4.3	Storage	4
1.5	Nameplate	4
<b>2</b>	<b>Product Description</b>	<b>5</b>
2.1	Introduction	5
2.2	Measuring Principle	5
2.3	Specifications	6
2.3.1	Operational Specifications	6
2.3.2	Electrical Specifications	6
2.3.3	Mechanical Specifications	6
2.4	Dimensional Drawings	7
<b>3</b>	<b>Installation</b>	<b>8</b>
3.1	Installation Procedure	8
3.1.1	Installation on tanks with obstruction	8
3.1.2	Installation on tanks with domed top	9
3.2	Installation on vessels with conical bottom	9
3.3	Installation on vessels with inflowing medium	9
<b>4</b>	<b>Electrical Connection</b>	<b>10</b>
4.1	Power Supply Connection	10
4.2	Connection to the RS232	11
4.3	Connection to the RS485	12
4.4	Connection of communication port with PC	12
<b>5</b>	<b>Configuration</b>	<b>13</b>
5.1	Inside Tank Calibration	13
5.2	Outside Tank Calibration	14
<b>6</b>	<b>Maintenance</b>	<b>15</b>
<b>7</b>	<b>Troubleshooting</b>	<b>16</b>
7.1	Mounting Influence	16
7.2	Standpipe Influence	17
7.3	Dusty Application	17
7.4	Condensation on Transducer Face	18
7.5	Tall Narrow Tank with Welding Joints	18
7.6	Ultrasonic on Crude Oil	19

## 1 Safety Instructions

### 1.1 Intended Use

The measuring device described in this operating instruction manual is used for the level measurement. It can be used for applications such as water treatment and monitoring, food processing, pharmaceutical and wastewater industry.

### 1.2 Safety Instructions from the Manufacturer

#### 1.2.1 Disclaimer

The manufacturer will not be held accountable for any damage that happens by using its product, including, but not limited to direct, indirect, or incidental and consequential damages.

Any product purchased from the manufacturer is warranted in accordance with the relevant product documentation and our Terms and Conditions of Sale.

The manufacturer has the right to modify the content of this document, including the disclaimer, at any time for any reason without prior notice, and will not be answerable in any way for the possible consequence of such changes.

#### 1.2.2 Product Liability and Warranty

The operator shall bear authority for the suitability of the device for the specific application. The manufacturer accepts no liability for the consequences of misuse by the operator. Wrong installation or operation of the devices (systems) will cause the warranty to be void. The respective Terms and Conditions of Sale, which forms the basis for the sales contract shall also apply.

#### 1.2.3 Information Concerning the Documentation

To prevent any injury to the operator or damage to the device it is essential to read the information in this document and the applicable national standard safety instructions. This operating manual contain all the information that is required in various stages, such as product identification, incoming acceptance and storage, mounting, connection, operation and commissioning, troubleshooting, maintenance, and disposal.

### 1.3 Safety Precautions

You must read these instructions carefully prior to installing and commissioning the device. These instructions are an important part of the product and must be kept for future reference. Only by observing these instructions, optimum protection of both personnel and the environment, as well as safe and fault-free operation of the device can be ensured.

For additional information that are not discussed in this manual, contact the manufacturer

### Warnings and Symbols Used

The following safety symbol marks are used in this operation manual and on the instrument.



WARNING

---

Indicates a potentially hazardous situation which, if not avoided, could result in death or serious injury

---



CAUTION

---

Indicates a potentially hazardous situation which, if not avoided, may result in minor or moderate injury. It may also be used to alert against unsafe practices.

---



NOTE

---

Indicates that operating the hardware or software in this manner may damage it or lead to system failure.

---

## 1.4 Packaging, Transportation, and Storage

### 1.4.1 Packaging

The original package consists of

1. Tek-Sound 4200A Explosion Proof Ultrasonic Level Transmitter
2. Documentation
3. Packing Box



### 1.4.2 Transportation

- Avoid impact shocks to the device and prevent it from getting wet during transportation.
- Verify local safety regulations, directives, and company procedures with respect to hoisting, rigging, and transportation of heavy equipment.
- Transport the product to the installation site using the original manufacturer’s packing whenever possible.

### 1.4.3 Storage

If this product is to be stored for a long period of time before installation, take the following precautions:

- Store your product in the manufacturer’s original packing used for shipping.
- Storage location should conform to the following requirements:
  - Free from rain and water
  - Free from vibration and impact shock
  - At room temperature with minimal temperature and humidity variation
- Before storing a used flowmeter remove any fluid from the flowmeter line completely. Properties of the instrument can change when stored outdoors.

## 1.5 Nameplate

The nameplate lists the order number and other important information, such as design details and technical data



Check the device nameplate to ensure that the device is delivered according to your order. Check for the correct supply voltage printed on the nameplate.

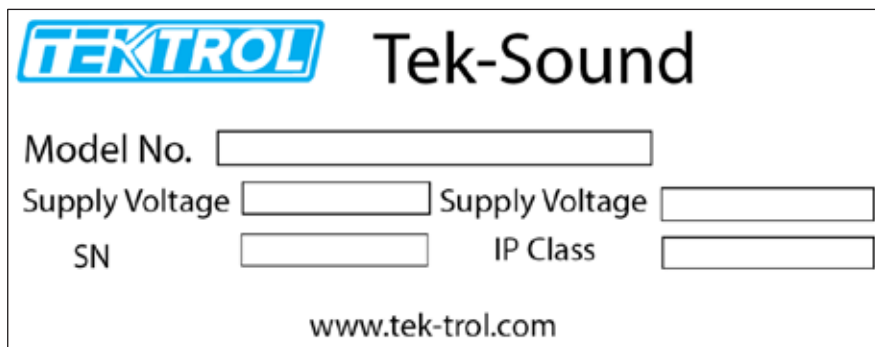

**TEKTROL** Tek-Sound

Model No.

Supply Voltage  Supply Voltage

SN  IP Class

www.tek-trol.com

## 2 Product Description

This section covers the reference and specification data, as well as ordering information.

### 2.1 Introduction

Tek-Sound 4200A Explosion Proof Ultrasonic Level Transmitter have commonly used level measurement instruments used in several industries for the continuous measurement of the level and volume of different media in open and closed tanks and for flow measurement in open channels. They are a cost-effective, reliable, and accurate solution in a wide array of applications involving both solids and liquids. Since they are non-contact devices, they require minimal maintenance and suffer minimal wear and tear. Additionally, this also ensures that they can be used under difficult process conditions.

### 2.2 Measuring Principle

An ultrasonic transmitter measures the level of a medium based on the propagation time of sound waves between a transducer and the surface of the medium. It consists of a transducer with a piezoelectric crystal that converts the electrical energy generated by the transmitter into sound waves. These sound waves are transmitted towards the surface of the medium and reflected back to the transducer where the piezoelectric crystal then converts them into an electrical signal. The transmitter measures the time taken by the waves to be emitted and reflected by the surface and return to the transducer. The distance between the transmitter and the medium surface is then calculated using the time of flight of the waves and the speed of sound.

The distance is therefore calculated using the following formula:

$$Distance = \frac{(Speed\ of\ Sound * Time\ of\ Flight)}{2}$$

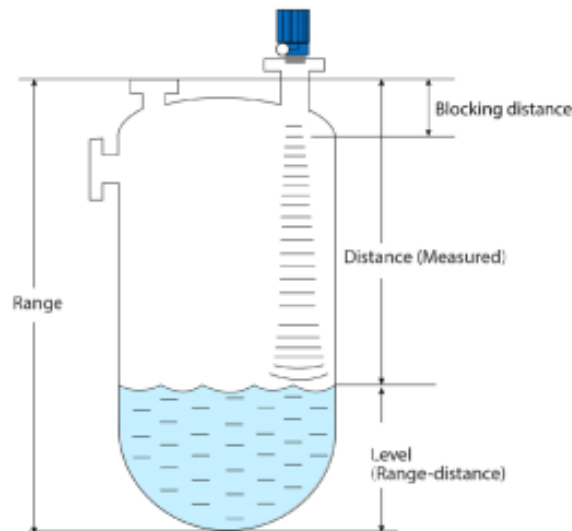

## 2.3 Specifications

### 2.3.1 Operational Specifications

Accuracy	+/-0.10% of max. range (in a lab using 4-20 mA current output)
	+/-0.25% of max. range (typically in a field)
Response time	Standard unit 2 - 3 echos / sec.
	Fast protocol 10 - 30 echos / sec.
Beam angle	10-12° at -3dB
Loss of echo	Hold 1 min., 22 mA or 2 mA outputs
Temperature compensation	Inbuilt
Calibration	Push-button or programmable via optional communications port
Diagnostics	(Echo profile) via communications port
Temperature	-40°F to 140°F (- 40°C to 60°C) continuous operation
Pressure	5 bar max. using high temperature & pressure sensor

### 2.3.2 Electrical Specifications

Power	AC	115 VAC 60 Hz or 230 VAC 50 Hz (+/-20%), 1.7 VA
	DC	12 to 30 VDC, 0.07 A max. at 24 VDC R load = (Vs - 6) / 24 mA
Output		RS232 or RS485 or 4 to 20 mA

### 2.3.3 Mechanical Specifications

Conduit entry	½"NPT hole (PVC conduit only)
Enclosure	PVC-94V0 or aluminium
Ingress protection	NEMA 4X (IP66)



## 2.4 Dimensional Drawings

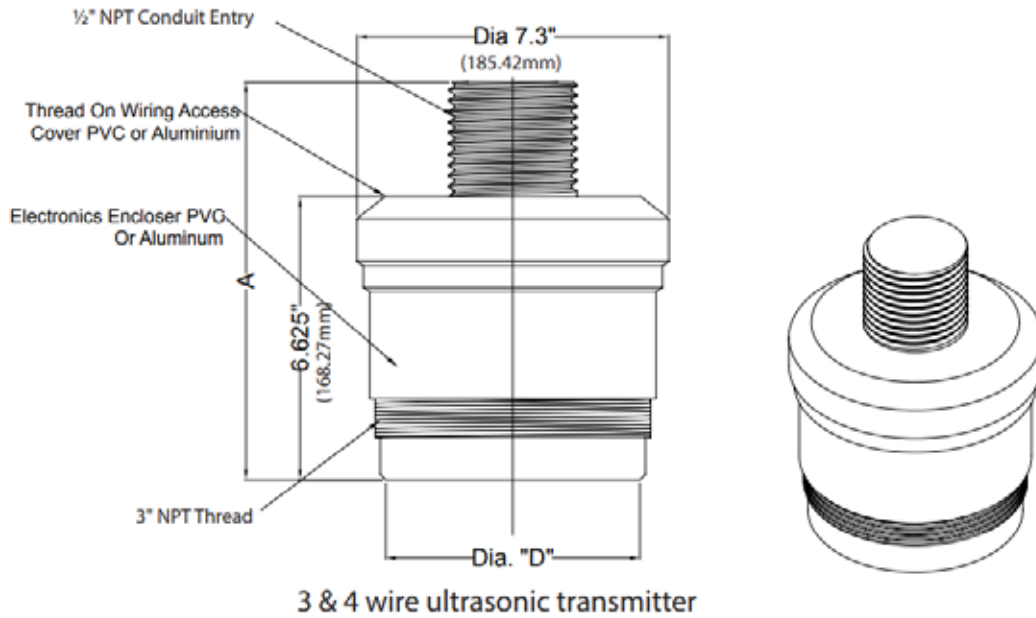

Model	Operating Range	Operating frequency	Mounting thread	Dimension" A"	Dimension" B"	Dimension" D"
4200A-045ULCX	60' (18.2 mm)	45 KHz	3"	7.75" (197mm)	3.0" (76.2mm)	3.0" (76.2mm)
4200A-052ULCX	50' (15.2 mm)	52 KHz	3"	9.3" (236mm)	3.05" (77.5mm)	2.2" (55.9mm)
4200A-070ULCX	30' (9.1 mm)	70 KHz	3"	8.5" (216mm)	2.25" (57.2mm)	1.8" (45.7mm)
4200A-080ULCX	20' (6.1 mm)	80 KHz	3"	8.5" (216mm)	2.25" (57.2mm)	1.8" (45.7mm)
4200A-081ULCX	16' (4.9 mm)	81 KHz	3"	8.4" (213mm)	2.1" (53.3mm)	1.5" (38.1mm)
4200A-148ULCX	9' (2.7 m)	148 KHz	1"	8.25" (210mm)	2.0" (50.8mm)	1.1" (27.9mm)

### 3 Installation

This section covers instructions on installation and commissioning. Installation of the device must be carried out by trained, qualified specialists authorized to perform such works.

 CAUTION

---

- When removing the instrument from hazardous processes, avoid direct contact with the fluid and the meter
  - All installation must comply with local installation requirements and local electrical code
- 

#### 3.1 Installation Procedure

This section provides the information concerning installation of the transmitter for safe operation. It provides the procedures and instruction for mounting, transmitter functions, and installation in specific applications.

##### 3.1.1 Installation on tanks with obstruction

During installation make sure that you do not have any large objects in front of transducer or antenna.

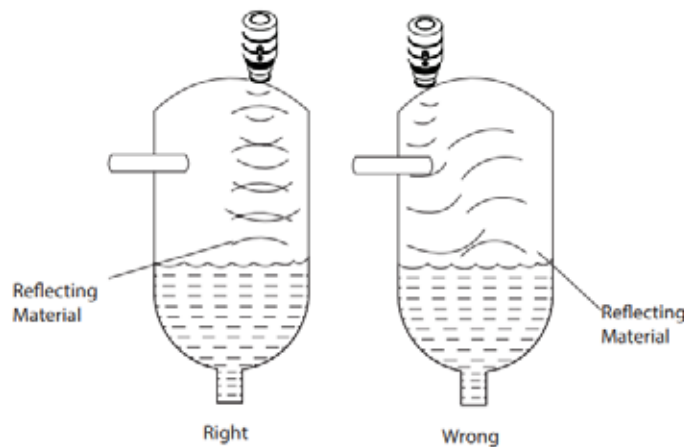

### 3.1.2 Installation on tanks with domed top

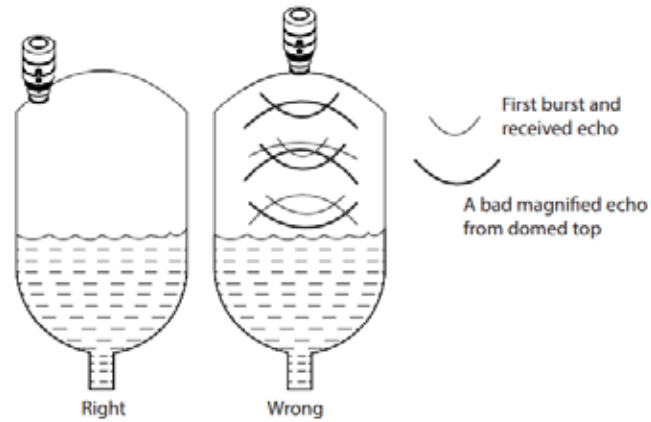

### 3.2 Installation on vessels with conical bottom

In vessels with conical bottom, it can be advantageous to mount the sensor in the center of the vessel, as measurement is then possible down to the lowest point of the vessel bottom.

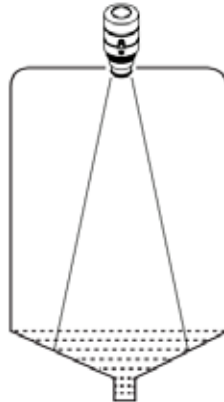

### 3.3 Installation on vessels with inflowing medium

Do not mount instruments in or above the filling stream. Make sure that you detect the product surface, not the inflowing product.

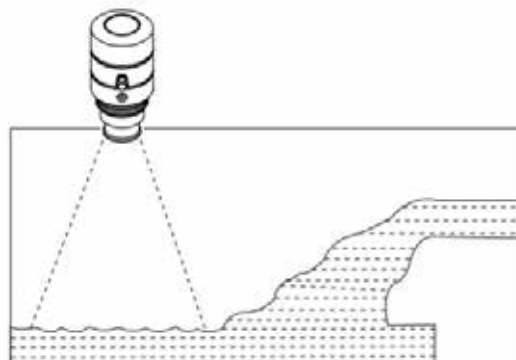

## 4 Electrical Connection

This section covers the all electrical connection requirement. Electrical connection of the device must be carried out by trained, qualified specialists authorized to perform such work by the installation site.

### WARNING

- Connect all electrical cables when the power is switched off. If the device does not have switch-off elements, then, overcurrent protection devices, lightning protection and/or energy isolating devices must be provided by the customer.
- The device must be grounded to a spot in accordance with regulations in order to protect personnel against electric shocks.

### NOTE

- When using the measuring device in hazardous areas, installation must comply with the corresponding national standards and regulations and the Safety Instructions or Installation or Control Drawings.

### 4.1 Power Supply Connection

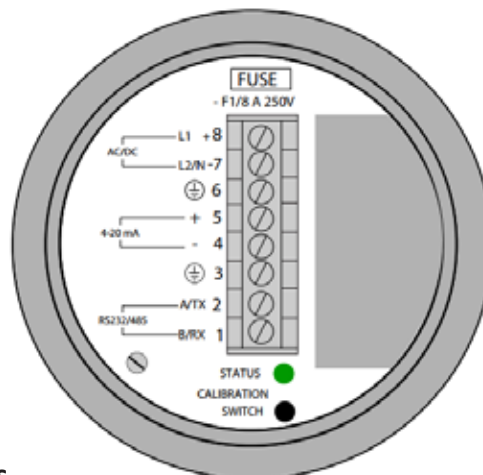

#### **For AC Sens**

Power: 3 Wire unshielded 22 AWG, 300 V Hook-up Wire

Current Output: 1 Pair shielded 24 AWG, 300 V Hook-up Wire

Communication: 1 Pair shielded 24 AWG, 300 V Hook-up Wire

**For DC Sensor —**

Power & Current output 3 Wire shielded 24 AWG, 300 V

Communication 1 Pair shielded 24 AWG, 300 V

**i** NOTE

- Ground shield at one end only
- All terminal block wiring must be rated for 250V
- Power input wiring must be protected by a 15A double pole circuit breaker

4.2 Connection to the RS232

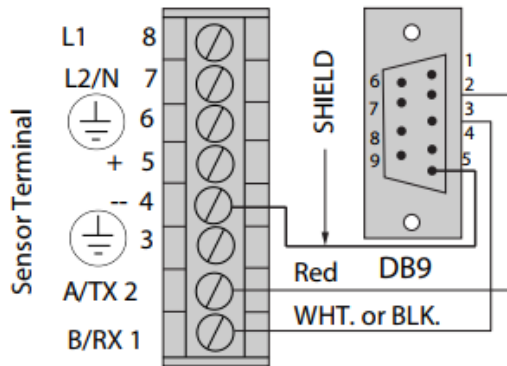

**i** NOTE

Connect the Shield to terminal #4

### 4.3 Connection to the RS485

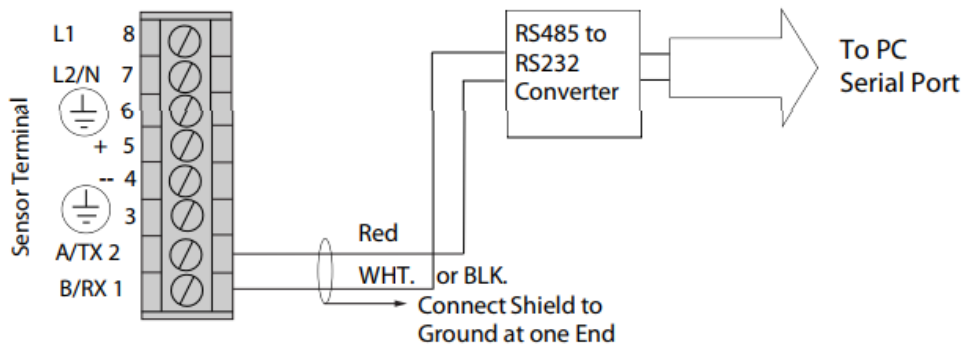

#### NOTE

Connect the Shield to terminal #4

### 4.4 Connection of communication port with PC

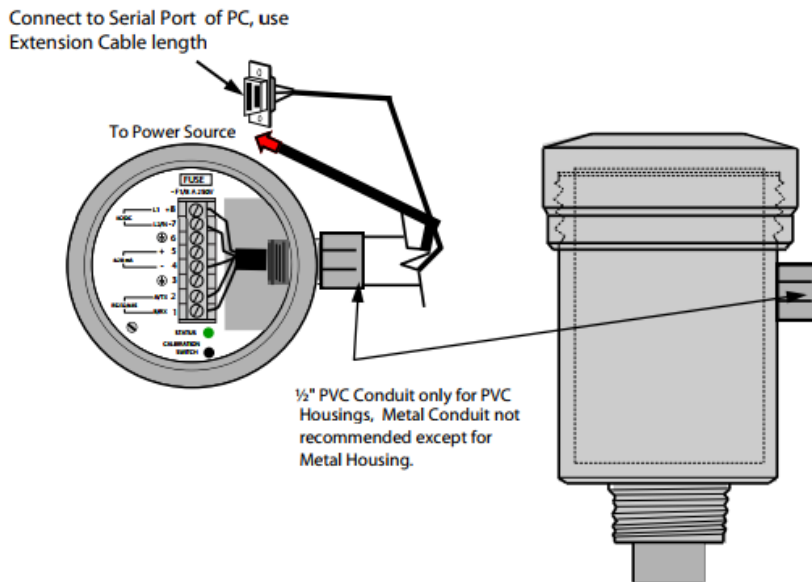

## 5 Configuration

This section covers the configuration and calibration of Tek-Sound 4200A Ultrasonic Level Transmitter.

### NOTE

---

Please calibrate the instrument according to the instructions given in this section, otherwise it could lead to measurement error.

---

### 5.1 Inside Tank Calibration

Follow the following guidelines for calibrating a tank using 4 mA to 20 mA or 20 mA to 4 mA output.

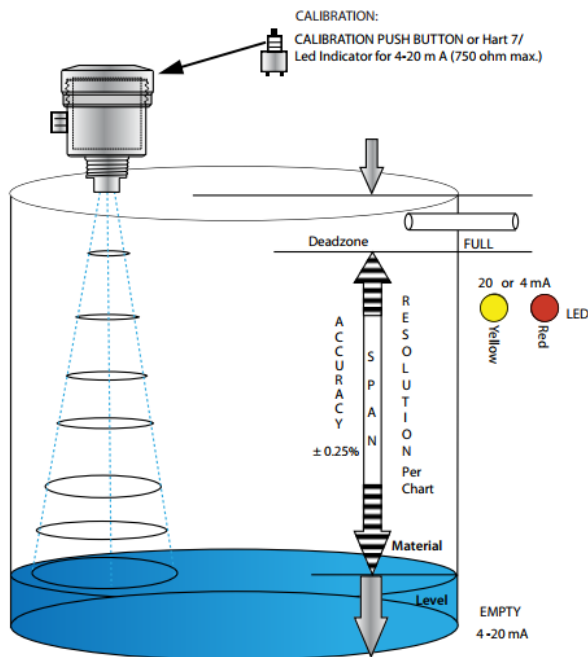

#### **FULL- Calibrate 20 mA or 4mA (Set Near Target)**

- Calibration mode LED colour is Blinking Green.
- Push button and hold until LED turns Yellow (20 mA) or push button and hold until LED turns Red (4 mA)
- Release button at Yellow or Red and observe LED -ashes to acknowledge the calibration.

## 5.2 Outside Tank Calibration

- For calibration of an Empty Tank (4 mA calibration), position the level device at a distance to a target equal to your empty tank level.
- For Full Tank Calibration (20mA Calibration) place the level device at a distance equal to a full tank.
- In case of the radar do the positioning for a full tank when the radar is off. Make sure the antenna is perpendicular to the metal target. After that, turn the unit on and wait a few seconds until the GREEN light is ON.
- The push button operation is explained in the **Inside Tank Calibration (Section 5.1)**.

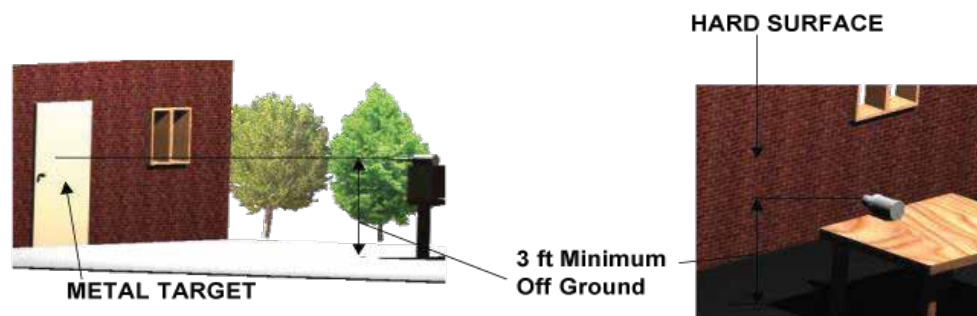



## 6 Maintenance

This section covers maintenance techniques and guidelines.

Occasionally check the transmitter face to ensure it remains clean and check that the cover seal, wiring, and cable glands are in good condition.

### **EMPTY- Calibrate 4 mA or 20 mA (Set Far Target)**

- Calibration mode LED colour is Blinking Green
- Push button and hold until LED turns Red (4 mA) or push button and hold until LED turns Yellow (20 mA)
- Release button at Yellow or Red and observe LED flashes to acknowledge the calibration

### **LOSS OF ECHO—22 mA or 3.5 mA**

- To choose 22mA press and hold button until the light goes off—2 flashes
- To choose 3.5mA press and hold button until the light goes off—1 flash

## 7 Troubleshooting

This section provides troubleshooting techniques for most common operating problems.

### 7.1 Mounting Influence

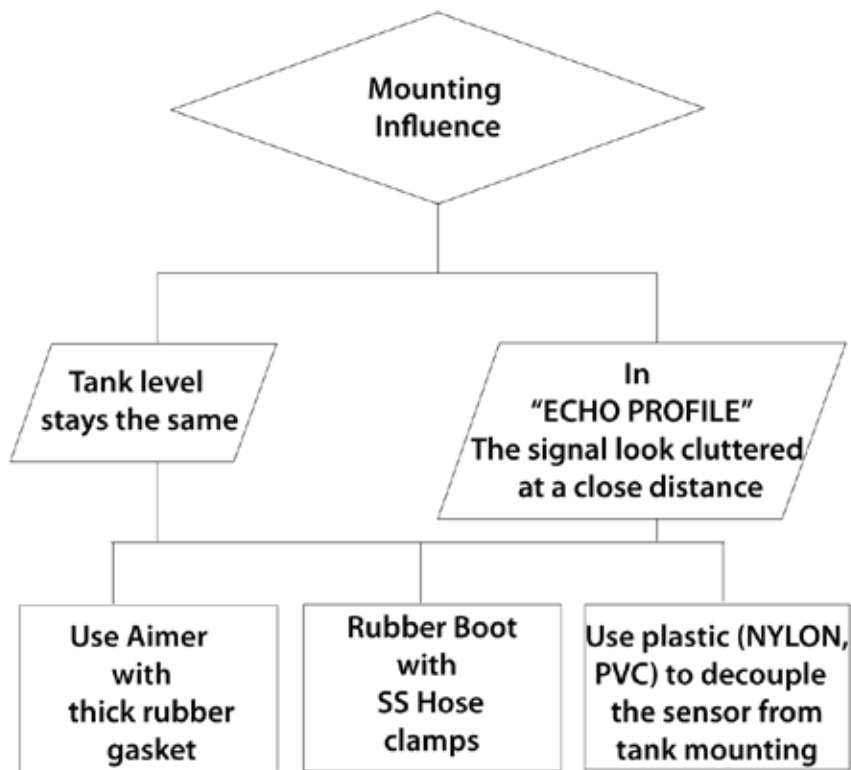

### 7.2 Standpipe Influence

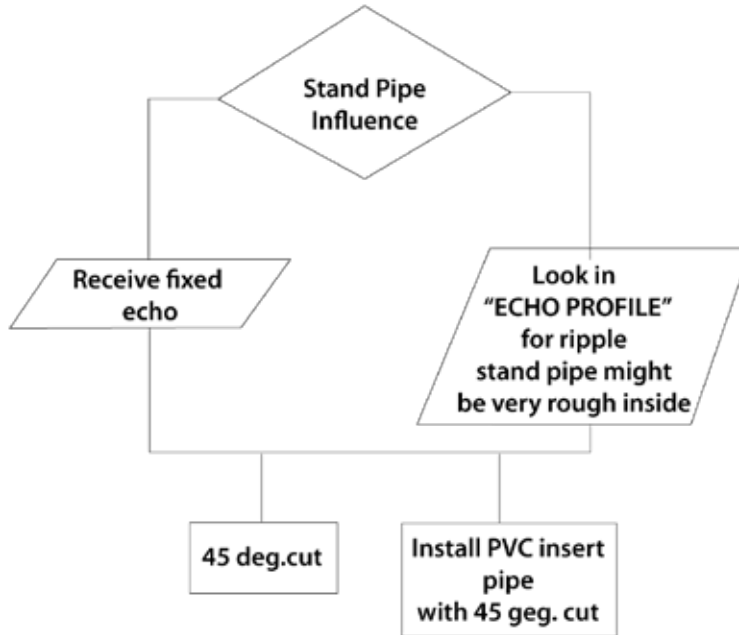

### 7.3 Dusty Application

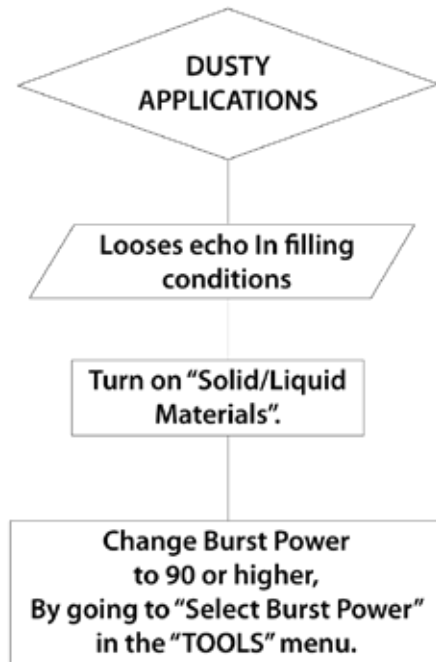

### 7.4 Condensation on Transducer Face

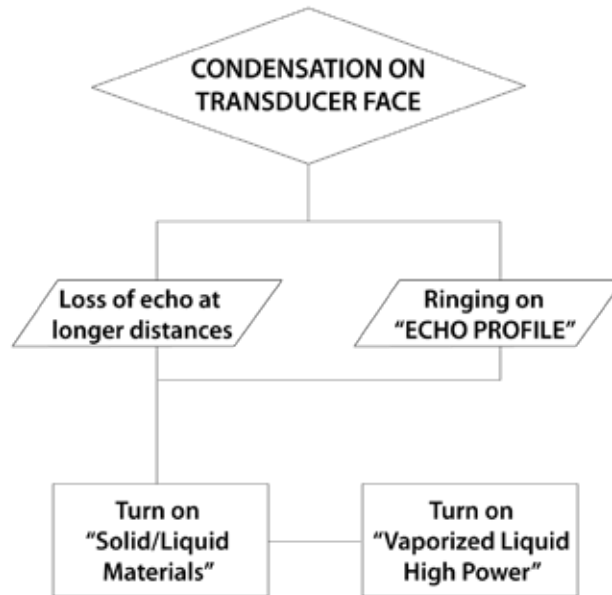

### 7.5 Tall Narrow Tank with Welding Joints

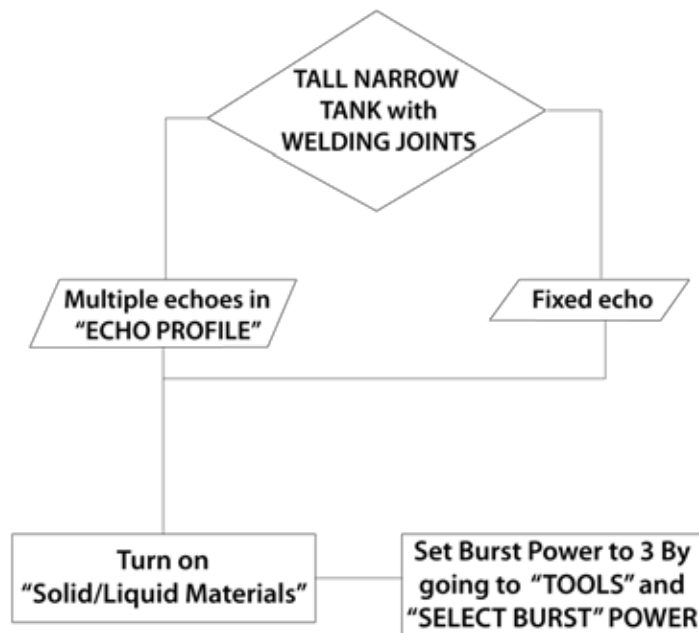

## 7.6 Ultrasonic on Crude Oil

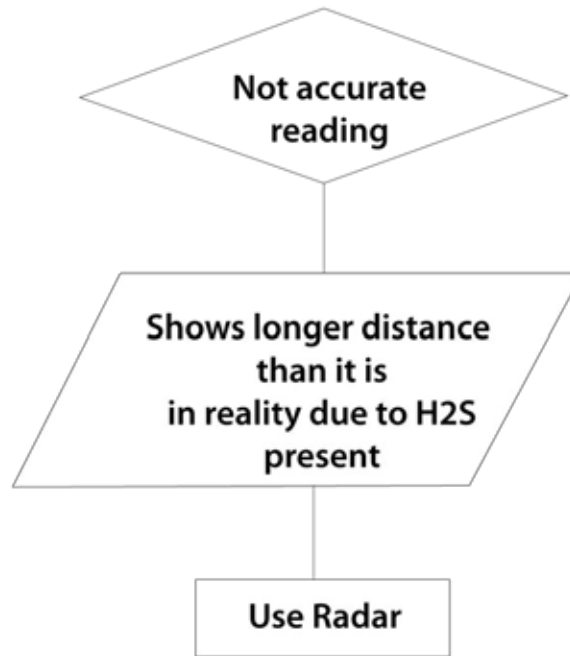



TEKMATION LLC reserves the right to change the designs and/or materials of its products without notice. The contents of this publication are the property of TEKMATON LLC and cannot be reproduced by any other party without written permission. All rights reserved. Copyright © 2020 TEKMATON LLC  
DOC:TEK/PO/INTL/20032/1/2020/4/01  
TEKMATION LLC



[www.tek-trol.com](http://www.tek-trol.com)

Tek-Trol is a fully owned subsidiary of TEKMATON LLC. We offer our customers a comprehensive range of products and solutions for process, power and oil & gas industries. Tek-Trol provides process measurement and control products for Flow, Level, Temperature & Pressure Measurement, Control Valves & Analyzer systems. We are present in 15 locations globally and are known for our knowledge, innovative solutions, reliable products and global presence.

### **Tek-Trol LLC**

796 Tek Drive Crystal Lake, IL 60014,  
USA  
Sales: +1 847-655-7428

### **Tek-Trol Solutions BV**

Florijnstraat 18, 4879 AH Etten-Leur,  
Netherlands  
Sales: +31 76-2031908

### **Tek-Trol Middle East FZE**

SAIF Zone, Y1-067, PO BOX No.  
21125, Sharjah, UAE  
Sales: +971-6526-8344

Support: +1 847-857-6076

Email: [tektrol@tek-trol.com](mailto:tektrol@tek-trol.com)

[www.tek-trol.com](http://www.tek-trol.com)

Flow | Level | Temperature | Pressure | Valves | Analyzers | Accessories | TekValSys