

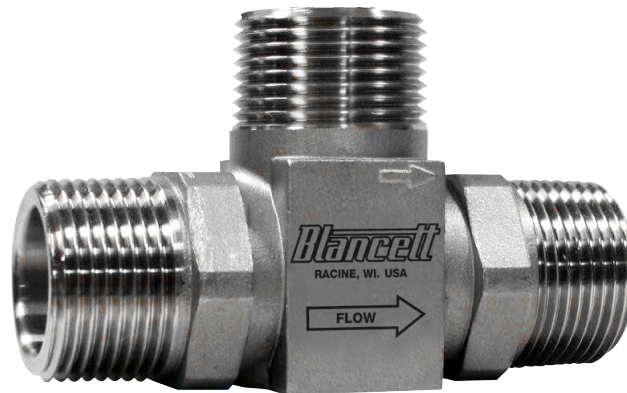

Turbine Flow Meter

1100 Series Turbine Meter



TUR-UM-00014-EN-08 (April 2021)

User Manual

CONTENTS

Introduction	3
Operating Principle	3
Specifications	4
Installation	4
Pressure Drop in Water	7
Operational Startup	7
Turbine Replacement	8
Turbine Replacement Kit Part Number	8
Turbine Assembly Removal	8
Disassembly	9
New Turbine Kit Installation	10
Part Number Information	11
Troubleshooting Guide	12

INTRODUCTION

Designed to withstand the demands of the most rigorous flow measurement applications, the Model 1100 turbine flow meter is reliable, rugged and cost effective. Originally developed for the secondary oil recovery market, the Model 1100 is an ideal meter for liquid flow measurement on or off the oil field.

The meter features a rugged 316 stainless steel housing and rotor support assemblies, CD4MCU stainless steel rotor, and abrasive-resistant tungsten carbide rotor, shaft, and journal bearings. The Model 1100 maintains measurement accuracy and mechanical integrity in the corrosive and abrasive fluids commonly found in oil field water flood projects and other industrial applications.

OPERATING PRINCIPLE

Fluid entering the meter passes through the inlet flow straightener that reduces its turbulent flow pattern and improves the fluid's velocity profile. Fluid then passes through the turbine, causing it to rotate at a speed proportional to the fluid velocity. As each turbine blade passes through the magnetic field, the blade generates an AC voltage pulse in the pickup coil at the base of the magnetic pickup (see [Figure 1](#)). These pulses produce an output frequency proportional to the volumetric flow through the meter. The output frequency represents flow rate and/or totalization of fluid passing through the turbine flow meter.

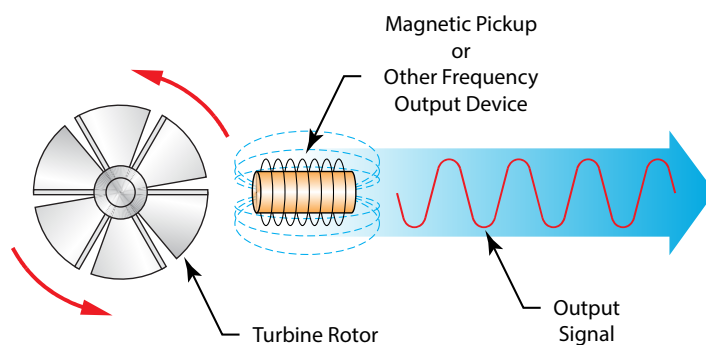
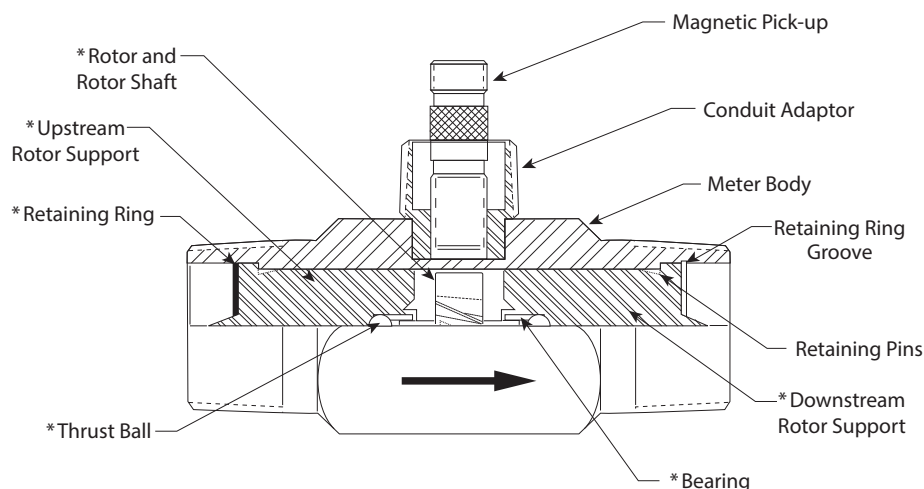

Figure 1: Schematic illustration of electric signal generated by rotor movement



NOTE: * Indicates parts supplied in repair kits.

Figure 2: Typical cross-section of B110-375...B111-121 turbine flow meter

SPECIFICATIONS

Materials of Construction	Body	316 stainless steel
	Rotor	CD4MCU stainless steel
	Rotor Shaft	Tungsten carbide
	Rotor Support	316 stainless steel
Operating Temperature	-150...350° F (-101...177° C)	
Pressure Rating*	800 or 5000 psi	
End Connections	NPT, BSP, Victaulic®, flange, hose barbed	
Turndown Ratio	10:1	
Accuracy	±1% of reading for 7/8 in. and larger meters	
	±1% of reading over the upper 70% of the measuring range for 3/8, 1/2, and 3/4 in. meters	
Repeatability	±0.1%	
Calibration	Water (NIST traceable calibration)	
Pickup	PN:	B111109
	Description:	Standard Magnetic Pickup; -150...330° F (-101...165° C)
	Body Thread:	5/8-18 UNF
	Termination Type:	2-Pin MS
	Mounting Thread Electrical:	MS3106-10SL-4S
	Output:	MAG (mV Freq)
	Resistance:	1500 Ω ± 10%
	Gauss:	~1200
	Temperature Range:	-150...330° F (-101...165° C)
	Pinouts:	A=Coil, B=Coil (no polarity)
Certifications	CSA Class I Div 1, Groups C & D	
	Class II Div 1, Groups E, F & G: intrinsically safe**	
	CSA Class I Div 1 Groups C,D; complies to UL 1203 and CSA 22.2 No. 30	
	Met Labs File No. E112860 (for explosion proof models only)	

* Consult factory for pressure ratings for flanged meters.

** Consult factory for ordering options

INSTALLATION

⚠ WARNING

PRESSURE IN EXCESS OF ALLOWABLE RATING MAY CAUSE THE HOUSING TO BURST AND CAUSE SERIOUS PERSONAL INJURY.

⚠ AVERTISSEMENT

LA PRESSION AU-DESSUS DE L'ESTIMATION PERMISE PEUT FAIRE ÉCLATER ET CAUSER LE LOGEMENT LE DOMMAGE CORPOREL SÉRIEUX.

1. Check the internals of the flow meter for any foreign material. Make sure the turbine rotor spins freely prior to installation. Also, check fluid lines and remove any debris found.
2. Install the flow meter with the flow arrow, etched on the exterior of the meter body, pointing in the direction of fluid flow. Though the meter is designed to function in any position, where possible, install it horizontally with the conduit adapter facing upward.
3. Thread a magnetic pickup (Badger Meter model B111109 or equivalent) into the conduit adapter completely finger tight without forcing. Secure with a lock nut if supplied.
4. Install conduit or other fittings suitable for the installation area onto the conduit adapter hub on the flow meter.

All Badger Meter Model 1100 turbine meters use stainless steel and tungsten carbide construction materials. Make sure the operating fluid is compatible with these materials. Incompatible fluids can cause deterioration of internal components and cause a reduction in meter accuracy.

The measured liquid should be free of any large particles that may inhibit rotation of the turbine blades. If particles are present, install a mesh strainer upstream before operating the flow meter. See [Table 1](#) for strainer recommendations.

Part Number	Strainer Mesh	Clearance	Filter Size
B110-375	60	0.0092 in.	260 µm
B110-500	60	0.0092 in.	260 µm
B110-750	60	0.0092 in.	260 µm
B110-875	60	0.0092 in.	260 µm
B111-110	60	0.0092 in.	260 µm
B111-115	20	0.0340 in.	0.86 mm
B111-120	10	0.0650 in.	1.6 mm
B111-121	20	0.0340 in.	0.86 mm
B111-130, B117-130	8	0.0900 in.	2.3 mm
B111-140, B117-140	10	0.0650 in.	1.6 mm
B111-160	4	0.1875 in.	4.8 mm
B111-180	8	0.0900 in.	2.3 mm
B111-200	4	0.1875 in.	4.8 mm

Table 1: Strainer mesh installation details

The preferred plumbing setup is one containing a bypass line (see [Figure 3 on page 6](#)) that allows meter inspection and repair without interrupting flow. If a bypass line is not used, it is important that all control valves be located downstream of the flow meter (see [Figure 4 on page 6](#)).

CAUTION

STRIKING AN EMPTY METER WITH HIGH VELOCITY FLOW STREAM CAN CAUSE DAMAGE.

ATTENTION

DES DOMMAGES PEUVENT ÊTRE PROVOQUÉS EN FRAPPANT UN MÈTRE VIDE AVEC UN JET D'ÉCOULEMENT DE VITESSE ÉLEVÉE.

Any restriction in the flow line may cause the liquid to flash. If necessary, install air eliminators so that the meter is not incorrectly measuring entrained air or gas.

Badger Meter recommends installation of a minimum straight pipe length, equal to ten (10) pipe diameters on the upstream side and five (5) diameters on the downstream side of the flow meter. Otherwise, meter accuracy may be affected. Piping should be the same size as the meter bore or threaded port size.

Severe pulsation and mechanical vibration affect accuracy and shorten the life of the meter. If this condition is present, consider using a flow meter possessing superior resistance to pulsation and vibration like the Badger Meter QuikSert. Do not locate the flow meter or connection cable close to electric motors, transformers, sparking devices, high voltage lines, or place connecting cable in conduit with wires furnishing power for such devices. These devices can induce false signals in the flow meter coil or cable, causing the meter to read inaccurately.

If problems arise with the flow meter, consult the [Troubleshooting Guide on page 12](#). If further problems arise, consult the factory.

Replace damaged internal components of the turbine flow meter with a turbine meter repair kit available from Badger Meter. See [Turbine Replacement on page 8](#).

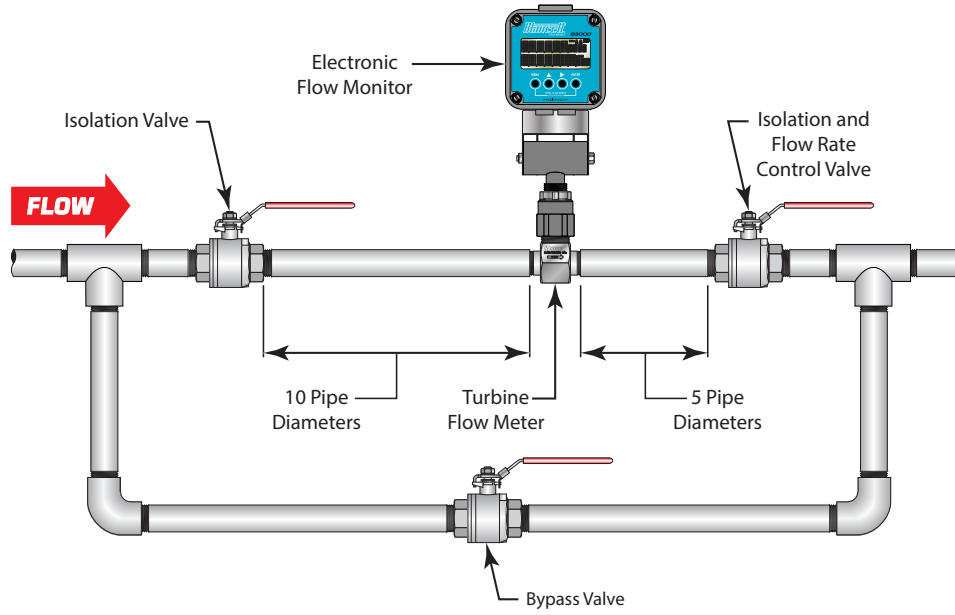

Figure 3: Meter installation with a bypass line

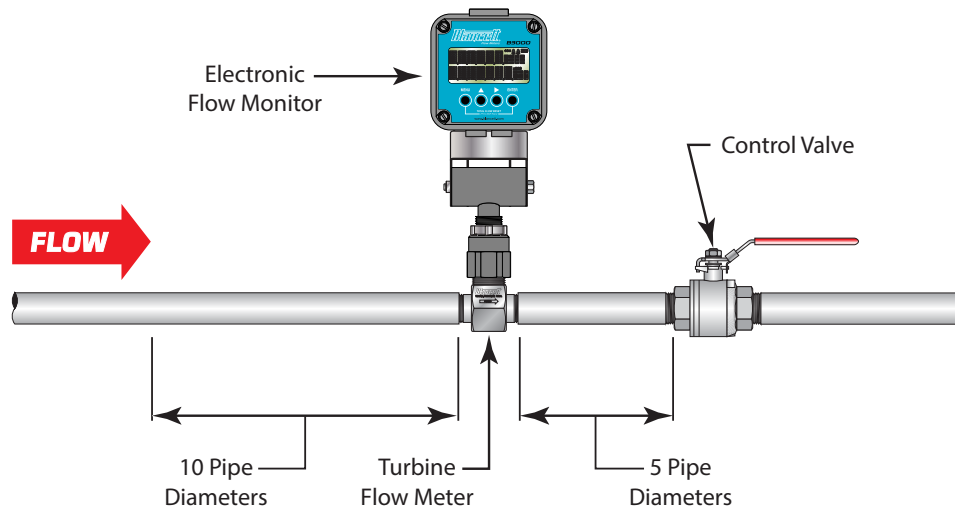

Figure 4: Meter installation without a bypass line

PRESSURE DROP IN WATER

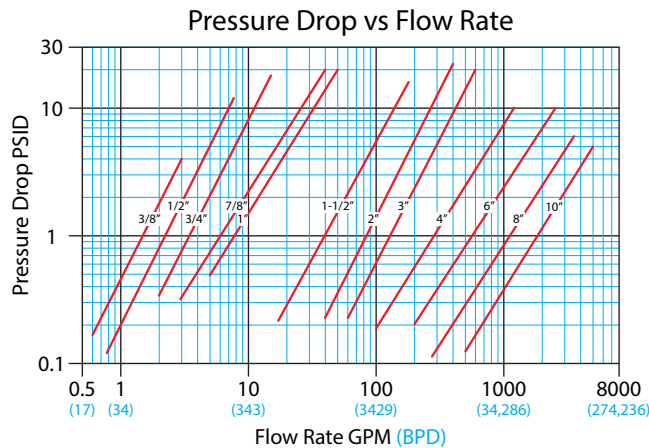

Figure 5: English units pressure drops

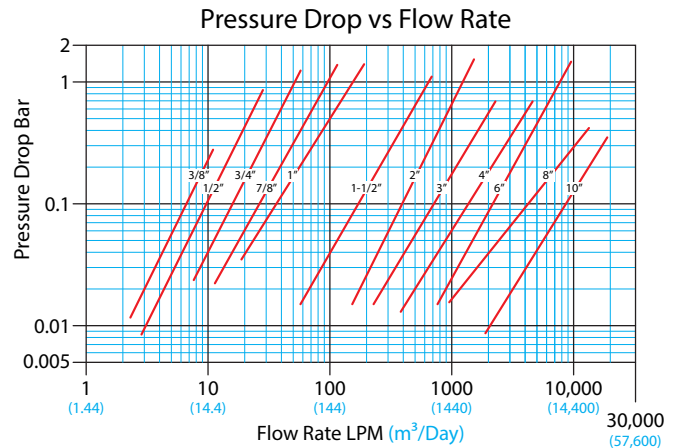

Figure 6: Metric units pressure drops

OPERATIONAL STARTUP

Follow these steps when installing and starting the meter.

⚠ WARNING

MAKE SURE TO SHUT OFF FLUID FLOW AND RELEASE PRESSURE IN THE LINE BEFORE ATTEMPTING TO INSTALL THE METER IN AN EXISTING SYSTEM.

⚠ AVERTISSEMENT

ASSUREZ-VOUS QUE LE FLUX DE FLUIDE A ÉTÉ COUPÉ ET DE LA PRESSION DANS LA LIGNE A ÉTÉ LIBÉRÉE AVANT D'ESSAYER D'INSTALLER LE MÈTRE DANS UN SYSTÈME ACTUEL.

After meter installation, close the isolation valves and open the bypass valve. Allow liquid to flow through the bypass valve for sufficient time to eliminate any air or gas in the flow line.

⚠ CAUTION

HIGH VELOCITY AIR OR GAS MAY DAMAGE THE INTERNAL COMPONENTS OF THE METER.

⚠ ATTENTION

DES DOMMAGES PEUVENT ÊTRE PROVOQUÉS EN FRAPPANT UN MÈTRE VIDE AVEC UN JET D'ÉCOULEMENT DE VITESSE ÉLEVÉE.

1. Open the upstream isolating valve slowly to eliminate hydraulic shock while charging the meter with the liquid. Open the valve to full open.
2. Open downstream isolating valve to permit meter to operate.
3. Close the bypass valve to a full closed position.
4. Adjust the downstream valve to provide the required flow rate through the meter.

NOTE: If necessary, use the downstream valve as a control valve.

TURBINE REPLACEMENT

The Model 1100 turbine flow meter uses wear-resistant moving parts to provide trouble-free operation and long service life. Designed for easy field service of a damaged flow meter, Model 1100 repair kits replace only the internal parts, not the entire flow meter. Repair parts use stainless steel alloys and tungsten carbide construction materials.

Each repair kit is factory calibrated to provide accuracy throughout the entire flow range. Each kit is complete and includes a new K-factor, which is the calibrated number of pulses generated by each gallon of liquid. Recalibration of the monitor or other electronics uses the K-factor to provide accurate output data.

NOTE: If the meter repair kit part number ends in NCC (no calibration), it was not factory calibrated. For these repair kits, use the nominal K-factor.

Turbine Replacement Kit Part Number

Flow Meter Size	Replacement Kit Fits Meter Part Number	Repair Kit Part Number
3/8 in.	B110-375, B110-375-1/2	B251-102
1/2 in.	B110-500, B110-500-1/2	B251-105
3/4 in.	B110-750, B110-750-1/2	B251-108
7/8 in.	B110-875	B251-109
1 in.	B111-110	B251-112
1-1/2 in.	B111-115	B251-116
2 in. Low	B111-121	B251-116
2 in.	B111-120	B251-120
3 in.	B111-130	B251-131
4 in.	B111-140	B251-141
6 in.	B111-160	B251-161
8 in.	B111-180	B251-181
10 in.	B111-200	B251-200
Standard Magnetic Pick-up	All Meter Sizes	B111109

Table 2: Repair kit part numbers

Turbine Assembly Removal

⚠ WARNING

HIGH-PRESSURE LEAKS ARE DANGEROUS AND MAY CAUSE PERSONAL INJURY. MAKE SURE TO SHUT OFF FLUID FLOW AND RELEASE RESIDUAL PRESSURE IN THE LINE BEFORE ATTEMPTING TO REMOVE THE METER.

⚠ AVERTISSEMENT

LES FUITES À HAUTE PRESSION SONT DANGEREUSES ET PEUVENT CAUSER LE DOMMAGE CORPOREL. ASSUREZ-VOUS QUE LE FLUX DE FLUIDE A ÉTÉ COUPÉ ET DE LA PRESSION DANS LA LIGNE A ÉTÉ LIBÉRÉE AVANT D'ESSAYER D'ENLEVER LE MÈTRE.

Disassembly

1. Refer to [Figure 7](#), [Figure 8](#) and [Figure 9](#) for relative positions of repair kit components.
2. Remove the magnetic pickup from the meter body to avoid damage during repair.
3. Remove the retaining ring from one end of the meter.
4. Remove the rotor support from the body. If the rotor support is jammed in the body, use a pair of pliers or vise-grips to break the rotor support free.
5. The rotor may also be removed at this time.

NOTE: 4 in. and larger meters have two retaining rings (one on either side of the rotor) that require removal before the rotor can be removed (see [Figure 9](#)).

6. Remove the retaining ring from the opposite side of the meter.
7. Remove the second rotor support.

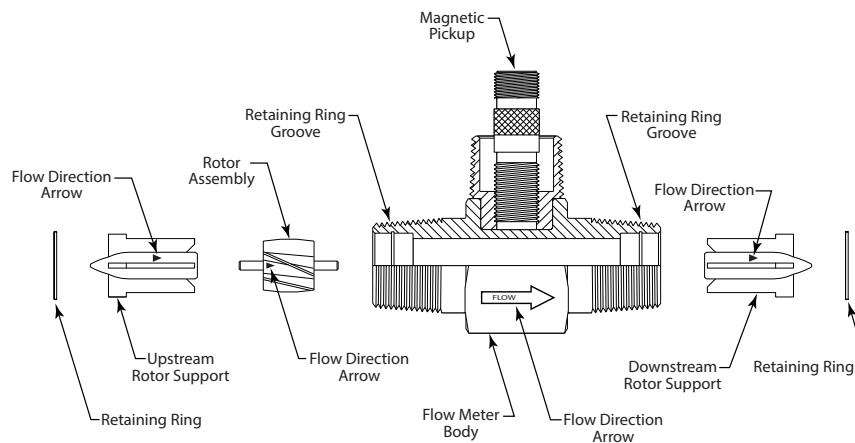

Figure 7: Component positions for B110-375...B111-115 and B111-121

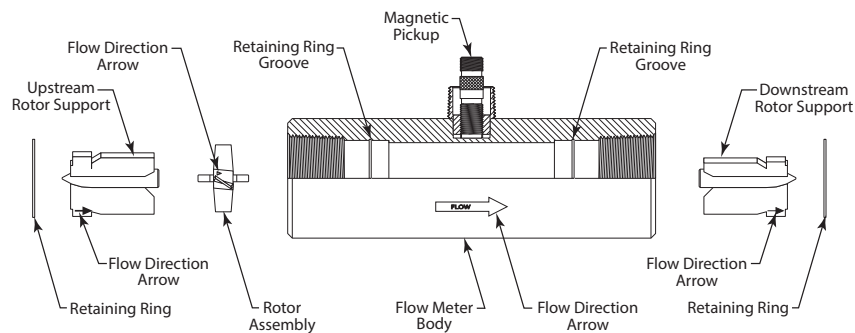

Figure 8: Component positions for B111-120 and B111-130

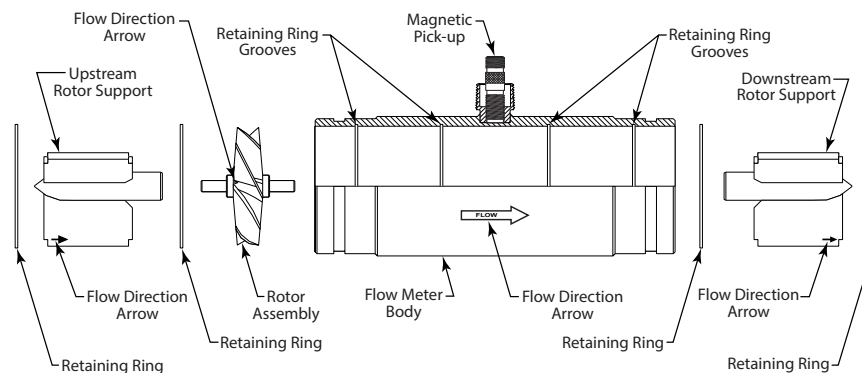

Figure 9: Component positions for B111-140 and B111-200

New Turbine Kit Installation

IMPORTANT

Before reassembly, note that an arrow is cast or engraved on each component. The arrow indicates the primary flow direction. When reassembled, the arrowheads must point in the direction of the fluid flow. The arrows must also be oriented in the up position on both rotor supports. The magnetic pickup side of the body signifies the up position. Performance of repair kit calibration is in the up position. Reinstallation of the repair kit in the up position provides continuation of accurate measurements. [Figure 7](#), [Figure 8](#), and [Figure 9](#) show the proper alignment and orientation of the repair kits.

NOTE: Fractional size (3/8 in., 1/2 in. and 3/4 in.) rotors do not contain a cast or engraved arrow. However, a colored cap on the downstream side of the rotor shaft indicates flow direction. Remove this cap before assembly, noting flow direction.

1. Install one of the rotor supports into the body bore, noting the orientation of the arrow.
2. Secure a retaining ring in the groove. Check for complete installation of retaining rings in each groove.

NOTE: 4 in. and larger meters have a retaining ring at both ends of the rotor (see [Figure 9](#)).

3. Insert the rotor and second rotor support in the opposite side of the body, noting the orientation of the arrow.
4. Secure the second retaining ring in the opposite groove, using the same procedure as in step 2 above.

CAUTION

EXCESS AIR PRESSURE MAY DAMAGE THE ROTOR AND BEARINGS BY OVER SPINNING.

ATTENTION

LA PRESSION ATMOSPHÉRIQUE EXCESSIVE PEUT ENDOMMAGER LE ROTOR ET LES ROULEMENTS PRÈS AU-DESSUS DE LA ROTATION.

5. Check the meter by lightly puffing air through the assembly. If the rotor does not turn freely, disassemble the meter and remove anything that might obstruct movement of the rotor.

NOTE: At this time, electronics require recalibration. Refer to the display's user manual. If there are any questions on recalibration, contact Badger Meter, Inc. or the manufacturer of the associated electronics.

6. Install the magnetic pickup.

PART NUMBER INFORMATION

Part Number	Bore Size	End Connections	Max. PSI	Flow Ranges			Strainer Mesh	Approx. K-factor Pulse/Gal	Meter Weight (lb)	End to End Length
				gpm (lpm)	bpd	m3/d				
B110-375-½	3/8 in. (9.5 mm)	1/2 in. male NPT	5000	0.6...3 (2.3...11.4)	20...100	3.3...16	60	18000	1	3.00 in. (76.20 mm)
B110-500-½	1/2 in. (12.7 mm)	1/2 in. male NPT	5000	0.75...7.5 (2.8...28.4)	25...250	4.1...41	60	13000	1	3.00 in. (76.20 mm)
B110-750-½	3/4 in. (19.1 mm)	1/2 in. male NPT	5000	2...15 (7.6...56.7)	68...515	10.9...81.75	60	3300	1	3.00 in. (76.20 mm)
B110-375	3/8 in. (9.5 mm)	1 in. male NPT	5000	0.6...3 (2.3...11.4)	20...100	3.3...16	60	18000	2	4.00 in. (101.60 mm)
B110-500	1/2 in. (12.7 mm)	1 in. male NPT	5000	0.75...7.5 (2.8...28.4)	25...250	4.1...41	60	13000	2	4.00 in. (101.60 mm)
B110-750	3/4 in. (19.1 mm)	1 in. male NPT	5000	2...15 (7.5...56.7)	68...515	10.9...81.75	60	3300	2	4.00 in. (101.60 mm)
B110-875	7/8 in. (22.2 mm)	1 in. male NPT	5000	3...30 (11.4...113.6)	100...1000	16...160	60	3100	2	4.00 in. (101.60 mm)
B111-110	1 in. (25.4 mm)	1 in. male NPT	5000	5...50 (18.9...189.3)	170...1700	27.25...272.5	40	870	2	4.00 in. (101.60 mm)
B111-115	1-1/2 in. (38.1 mm)	1-1/2 in. male NPT	5000	15...180 (56.8...681.4)	515...6000	82...981	20	330	5	6.00 in. (152.40 mm)
B111-121	1-1/2 in. (38.1 mm)	2 in. male NPT	5000	15...180 (56.8...681.4)	515...6000	82...981	20	330	6	6.00 in. (152.40 mm)
B311-066	1-1/2 in. (38.1 mm)	2 in. grooved end	5000	15...180 (56.8...681.4)	515...6000	82...981	20	330	6	6.00 in. (152.40 mm)
B111-120	2 in. (50.8 mm)	2 in. female NPT	5000	40...400 (151.4...1514.2)	1300...13000	218...2180	20	52	14	10.00 in. (245.00 mm)
B311-004	3 in. (76.2 mm)	3 in. male NPT	800	60...600 (227.1...2271.2)	2100...21000	327...3270	10	57	15	12.50 in. (317.50 mm)
B111-130	3 in. (76.2 mm)	3 in. grooved end	800	60...600 (227.1...2271.2)	2100...21000	327...3270	10	57	15	12.50 in. (317.50 mm)
B311-084	4 in. (101.6 mm)	4 in. male NPT	800	100...1200 (378.5...4542.5)	3400...41000	545...6540	10	29	20	12.00 in. (304.80 mm)
B111-140	4 in. (101.6 mm)	4 in. grooved end	800	100...1200 (378.5...4542.5)	3400...41000	545...6540	10	29	20	12.00 in. (304.80 mm)
B311-085	6 in. (152.4 mm)	6 in. male NPT	800	200...2500 (757.1...9463.5)	6800...86000	1090...13626	4	7	46	12.00 in. (304.80 mm)
B111-160	6 in. (152.4 mm)	6 in. grooved end	800	200...2500 (757.1...9463.5)	6800...86000	1090...13626	4	7	46	12.00 in. (304.80 mm)
B111-180	8 in. (203.2 mm)	8 in. grooved end	800	350...3500 (1324.9...13248.9)	12000...120,000	1363...19076	4	3	56	12.00 in. (304.80 mm)
B111-200	10 in. (254 mm)	10 in. grooved end	800	500...5000 (1892.7...18927.1)	17000...171,000	2725...27252	4	1.6	80	12.00 in. (304.80 mm)

¹ Includes Standard Mag Pickup, p/n B111109, -150...330° F (-101...165° C), suitable for all mounting styles

TROUBLESHOOTING GUIDE

Trouble	Possible Cause	Remedy
Meter indicates higher than actual flow rate	Cavitation. Debris on rotor support. Build up of foreign material on meter bore. Gas in liquid.	Increase back pressure. Clean meter. Clean meter. Install gas eliminator ahead of meter.
Meter indicates lower than actual flow rate.	Debris on rotor. Worn bearing. Viscosity higher than calibrated.	Clean meter and add filter. Clean meter and add filter. Recalibrate monitor.
Erratic system indication, meter alone works well (remote monitor application only).	Ground loop in shielding.	Ground shield one place only. Look for internal electronic instrument ground. Reroute cables away from electrical noise.
Indicator shows flow when shut off.	Mechanical vibration causes rotor to oscillate without turning.	Isolate meter.
No flow indication. Full or partial open position.	Fluid shock, full flow into dry meter or impact caused bearing separation or broken rotor shaft.	Rebuild meter with repair kit and recalibrate monitor. Move to location where meter is full on startup or add downstream flow control valve.
Erratic indication at low flow, good indication at high flow.	Rotor has foreign material wrapped around it.	Clean meter and add filter.
No flow indication.	Faulty pickup.	Replace pickup.
System works perfect, except indicates lower flow over entire range.	By-pass flow, leak.	Repair or replace bypass valves, or faulty solenoid valves.
Meter indicating high flow, upstream piping at meter smaller than meter bore.	Fluid jet impingement on rotor.	Change piping.
Meter indicating low flow, upstream piping at meter smaller than meter bore.	Viscosity lower than calibrated.	Change temperature, change fluid or recalibrate meter.

Control. Manage. Optimize.

Blancett is a registered trademark of Badger Meter, Inc. Other trademarks appearing in this document are the property of their respective entities. Due to continuous research, product improvements and enhancements, Badger Meter reserves the right to change product or system specifications without notice, except to the extent an outstanding contractual obligation exists. © 2021 Badger Meter, Inc. All rights reserved.